



Hewlett Packard
Enterprise

HPE ProLiant DL360p Gen8 Server

Maintenance and Service Guide

Abstract

This guide describes identification and maintenance procedures, diagnostic tools, specifications, and requirements for hardware components and software. This guide is for an experienced service technician. Hewlett Packard Enterprise assumes you are qualified in the servicing of computer equipment, trained in recognizing hazards in products, and are familiar with weight and stability precautions.

Part Number: 664727-004aR
November 2015
Edition: 5

© Copyright 2012, 2015 Hewlett Packard Enterprise Development LP

The information contained herein is subject to change without notice. The only warranties for Hewlett Packard Enterprise products and services are set forth in the express warranty statements accompanying such products and services. Nothing herein should be construed as constituting an additional warranty. Hewlett Packard Enterprise shall not be liable for technical or editorial errors or omissions contained herein.

Microsoft® and Windows® are either registered trademarks or trademarks of Microsoft Corporation in the United States and/or other countries.

Intel® Xeon® is a registered trademarks of Intel Corporation in the U.S. and other countries.

Contents

Customer self repair	5
Parts only warranty service	5
Illustrated parts catalog	15
Mechanical components	15
System components	18
Removal and replacement procedures	25
Required tools	25
Preparation procedures	25
Power down the server	25
Extend the server from the rack	26
Safety considerations	26
Preventing electrostatic discharge	26
Symbols on equipment	26
Server warnings and cautions	27
Access panel	27
Drive blank	28
Hot-plug drive	28
Power supply blank	29
AC power supply	29
48V DC power supply option	30
Drive cage assembly	36
DVD-ROM or DVD-RW drive	37
Fan module	39
Fan blank	40
Flash-backed write cache procedures	40
Cache module	41
FBWC capacitor pack	41
Recovering data from the flash-backed write cache	42
Front video adapter	43
FlexibleLOM	43
Rack bezel	45
Air baffle	45
PCI riser cage	46
Expansion boards	47
PCIe riser board	48
DIMMs	48
Heatsink	49
Processor	52
System battery	57
System board	58
HP Trusted Platform Module	62
Cabling	63
Cabling overview	63
Hard drive backplane cabling	63
FBWC capacitor pack cabling	64
DVD-ROM and DVD-RW drive cabling	65
Chipset SATA cable option	65
Diagnostic tools	69
Troubleshooting resources	69
HPE Insight Diagnostics	69
HPE Insight Diagnostics survey functionality	69

HPE ROM-Based Setup Utility	70
Integrated Management Log	70
USB support and functionality	70
USB support	70
Internal USB functionality	71
Component identification	72
Front panel components	72
Front panel LEDs and buttons	74
Rear panel components	76
Rear panel LEDs and buttons	77
System board components	78
DIMM slots	79
System maintenance switch	79
NMI jumper	80
Systems Insight Display LEDs	80
Systems Insight Display LED combinations	81
Device numbers	82
Hot-plug drive LED definitions	83
Fan modules	84
Storage and expansion diagram	85
Specifications	86
Environmental specifications	86
Server specifications	86
Power supply specifications	86
HPE 460W Common Slot Gold Hot Plug Power Supply (92% efficiency)	87
HPE 460W Common Slot Platinum Plus Hot Plug Power Supply (94% efficiency)	87
HPE 500W Common Slot 277VAC Hot Plug Power Supply (94% efficiency)	88
HPE 750W Common Slot 277VAC Hot Plug Power Supply (94% efficiency)	88
HPE 750W Common Slot Titanium Hot Plug Power Supply (96% efficiency)	88
HPE 750W Common Slot Gold Hot Plug Power Supply (92% efficiency)	89
HPE 750W Common Slot Platinum Plus Hot Plug Power Supply (94% efficiency)	89
HPE 750W Common Slot -48VDC Hot Plug Power Supply (94% efficiency)	90
HPE 1200W Common Slot Platinum Plus Hot Plug Power Supply (94% efficiency)	90
Hot-plug power supply calculations	91
Acronyms and abbreviations	92
Documentation feedback	94
Index	95

Customer self repair

Hewlett Packard Enterprise products are designed with many Customer Self Repair (CSR) parts to minimize repair time and allow for greater flexibility in performing defective parts replacement. If during the diagnosis period Hewlett Packard Enterprise (or Hewlett Packard Enterprise service providers or service partners) identifies that the repair can be accomplished by the use of a CSR part, Hewlett Packard Enterprise will ship that part directly to you for replacement. There are two categories of CSR parts:

- **Mandatory**—Parts for which customer self repair is mandatory. If you request Hewlett Packard Enterprise to replace these parts, you will be charged for the travel and labor costs of this service.
- **Optional**—Parts for which customer self repair is optional. These parts are also designed for customer self repair. If, however, you require that Hewlett Packard Enterprise replace them for you, there may or may not be additional charges, depending on the type of warranty service designated for your product.

NOTE: Some Hewlett Packard Enterprise parts are not designed for customer self repair. In order to satisfy the customer warranty, Hewlett Packard Enterprise requires that an authorized service provider replace the part. These parts are identified as "No" in the Illustrated Parts Catalog.

Based on availability and where geography permits, CSR parts will be shipped for next business day delivery. Same day or four-hour delivery may be offered at an additional charge where geography permits. If assistance is required, you can call the Hewlett Packard Enterprise Support Center and a technician will help you over the telephone. Hewlett Packard Enterprise specifies in the materials shipped with a replacement CSR part whether a defective part must be returned to Hewlett Packard Enterprise. In cases where it is required to return the defective part to Hewlett Packard Enterprise, you must ship the defective part back to Hewlett Packard Enterprise within a defined period of time, normally five (5) business days. The defective part must be returned with the associated documentation in the provided shipping material. Failure to return the defective part may result in Hewlett Packard Enterprise billing you for the replacement. With a customer self repair, Hewlett Packard Enterprise will pay all shipping and part return costs and determine the courier/carrier to be used.

For more information about the Hewlett Packard Enterprise CSR program, contact your local service provider. For the North American program, go to the Hewlett Packard Enterprise CSR website (<http://www.hpe.com/support/selfrepair>).

Parts only warranty service

Your Hewlett Packard Enterprise Limited Warranty may include a parts only warranty service. Under the terms of parts only warranty service, Hewlett Packard Enterprise will provide replacement parts free of charge.

For parts only warranty service, CSR part replacement is mandatory. If you request Hewlett Packard Enterprise to replace these parts, you will be charged for the travel and labor costs of this service.

Réparation par le client (CSR)

Les produits Hewlett Packard Enterprise comportent de nombreuses pièces CSR (Customer Self Repair = réparation par le client) afin de minimiser les délais de réparation et faciliter le remplacement des pièces défectueuses. Si pendant la période de diagnostic, Hewlett Packard Enterprise (ou ses partenaires ou mainteneurs agréés) détermine que la réparation peut être effectuée à l'aide d'une pièce CSR, Hewlett Packard Enterprise vous l'envoie directement. Il existe deux catégories de pièces CSR :

- **Obligatoire**—Pièces pour lesquelles la réparation par le client est obligatoire. Si vous demandez à Hewlett Packard Enterprise de remplacer ces pièces, les coûts de déplacement et main d'œuvre du service vous seront facturés.
- **Facultatif**—Pièces pour lesquelles la réparation par le client est facultative. Ces pièces sont également conçues pour permettre au client d'effectuer lui-même la réparation. Toutefois, si vous demandez à Hewlett Packard Enterprise de remplacer ces pièces, l'intervention peut ou non vous être facturée, selon le type de garantie applicable à votre produit.

REMARQUE: Certaines pièces Hewlett Packard Enterprise ne sont pas conçues pour permettre au client d'effectuer lui-même la réparation. Pour que la garantie puisse s'appliquer, Hewlett Packard Enterprise exige que le remplacement de la pièce soit effectué par un Mainteneur Agréé. Ces pièces sont identifiées par la mention "Non" dans le Catalogue illustré.

Les pièces CSR sont livrées le jour ouvré suivant, dans la limite des stocks disponibles et selon votre situation géographique. Si votre situation géographique le permet et que vous demandez une livraison le jour même ou dans les 4 heures, celle-ci vous sera facturée. Pour toute assistance, appelez le Centre d'assistance Hewlett Packard Enterprise pour qu'un technicien vous aide au téléphone. Dans les documents envoyés avec la pièce de rechange CSR, Hewlett Packard Enterprise précise s'il est nécessaire de lui retourner la pièce défectueuse. Si c'est le cas, vous devez le faire dans le délai indiqué, généralement cinq (5) jours ouvrés. La pièce et sa documentation doivent être retournées dans l'emballage fourni. Si vous ne retournez pas la pièce défectueuse, Hewlett Packard Enterprise se réserve le droit de vous facturer les coûts de remplacement. Dans le cas d'une pièce CSR, Hewlett Packard Enterprise supporte l'ensemble des frais d'expédition et de retour, et détermine la société de courses ou le transporteur à utiliser.

Pour plus d'informations sur le programme CSR de Hewlett Packard Enterprise, contactez votre Mainteneur Agréé local. Pour plus d'informations sur ce programme en Amérique du Nord, consultez le site Web Hewlett Packard Enterprise (<http://www.hpe.com/support/selfrepair>).

Service de garantie "pièces seules"

Votre garantie limitée Hewlett Packard Enterprise peut inclure un service de garantie "pièces seules". Dans ce cas, les pièces de rechange fournies par Hewlett Packard Enterprise ne sont pas facturées.

Dans le cadre de ce service, la réparation des pièces CSR par le client est obligatoire. Si vous demandez à Hewlett Packard Enterprise de remplacer ces pièces, les coûts de déplacement et main d'œuvre du service vous seront facturés.

Riparazione da parte del cliente

Per abbreviare i tempi di riparazione e garantire una maggiore flessibilità nella sostituzione di parti difettose, i prodotti Hewlett Packard Enterprise sono realizzati con numerosi componenti che possono essere riparati direttamente dal cliente (CSR, Customer Self Repair). Se in fase di diagnostica Hewlett Packard Enterprise (o un centro di servizi o di assistenza Hewlett Packard Enterprise) identifica il guasto come riparabile mediante un ricambio CSR, Hewlett Packard Enterprise lo spedisce direttamente al cliente per la sostituzione. Vi sono due categorie di parti CSR:

- **Obbligatorie**—Parti che devono essere necessariamente riparate dal cliente. Se il cliente ne affida la riparazione ad Hewlett Packard Enterprise, deve sostenere le spese di spedizione e di manodopera per il servizio.
- **Opzionali**—Parti la cui riparazione da parte del cliente è facoltativa. Si tratta comunque di componenti progettati per questo scopo. Se tuttavia il cliente ne richiede la sostituzione ad Hewlett Packard Enterprise, potrebbe dover sostenere spese aggiuntive a seconda del tipo di garanzia previsto per il prodotto.

NOTA: alcuni componenti Hewlett Packard Enterprise non sono progettati per la riparazione da parte del cliente. Per rispettare la garanzia, Hewlett Packard Enterprise richiede che queste parti siano sostituite da un centro di assistenza autorizzato. Tali parti sono identificate da un "No" nel Catalogo illustrato dei componenti.

In base alla disponibilità e alla località geografica, le parti CSR vengono spedite con consegna entro il giorno lavorativo seguente. La consegna nel giorno stesso o entro quattro ore è offerta con un supplemento di costo solo in alcune zone. In caso di necessità si può richiedere l'assistenza telefonica di un addetto del centro di supporto tecnico Hewlett Packard Enterprise. Nel materiale fornito con una parte di ricambio CSR, Hewlett Packard Enterprise specifica se il cliente deve restituire dei componenti. Qualora sia richiesta la resa ad Hewlett Packard Enterprise del componente difettoso, lo si deve spedire ad Hewlett Packard Enterprise entro un determinato periodo di tempo, generalmente cinque (5) giorni lavorativi. Il componente difettoso deve essere restituito con la documentazione associata nell'imballo di spedizione fornito. La mancata restituzione del componente può comportare la fatturazione del ricambio da parte di Hewlett Packard Enterprise. Nel caso di riparazione da parte del cliente, Hewlett Packard Enterprise sostiene tutte le spese di spedizione e resa e sceglie il corriere/vettore da utilizzare.

Per ulteriori informazioni sul programma CSR di Hewlett Packard Enterprise, contattare il centro di assistenza di zona. Per il programma in Nord America fare riferimento al sito Web (<http://www.hpe.com/support/selfrepair>).

Servizio di garanzia per i soli componenti

La garanzia limitata Hewlett Packard Enterprise può includere un servizio di garanzia per i soli componenti. Nei termini di garanzia del servizio per i soli componenti, Hewlett Packard Enterprise fornirà gratuitamente le parti di ricambio.

Per il servizio di garanzia per i soli componenti è obbligatoria la formula CSR che prevede la riparazione da parte del cliente. Se il cliente invece richiede la sostituzione ad Hewlett Packard Enterprise dovrà sostenere le spese di spedizione e di manodopera per il servizio.

Customer Self Repair

Hewlett Packard Enterprise Produkte enthalten viele CSR-Teile (Customer Self Repair), um Reparaturzeiten zu minimieren und höhere Flexibilität beim Austausch defekter Bauteile zu ermöglichen. Wenn Hewlett Packard Enterprise (oder ein Hewlett Packard Enterprise Servicepartner) bei der Diagnose feststellt, dass das Produkt mithilfe eines CSR-Teils repariert werden kann, sendet Ihnen Hewlett Packard Enterprise dieses Bauteil zum Austausch direkt zu. CSR-Teile werden in zwei Kategorien unterteilt:

- **Zwingend**—Teile, für die das Customer Self Repair-Verfahren zwingend vorgegeben ist. Wenn Sie den Austausch dieser Teile von Hewlett Packard Enterprise vornehmen lassen, werden Ihnen die Anfahrt- und Arbeitskosten für diesen Service berechnet.
- **Optional**—Teile, für die das Customer Self Repair-Verfahren optional ist. Diese Teile sind auch für Customer Self Repair ausgelegt. Wenn Sie jedoch den Austausch dieser Teile von Hewlett Packard Enterprise vornehmen lassen möchten, können bei diesem Service je nach den für Ihr Produkt vorgesehenen Garantiebedingungen zusätzliche Kosten anfallen.

HINWEIS: Einige Hewlett Packard Enterprise Teile sind nicht für Customer Self Repair ausgelegt. Um den Garantieanspruch des Kunden zu erfüllen, muss das Teil von einem Hewlett Packard Enterprise Servicepartner ersetzt werden. Im illustrierten Teilekatalog sind diese Teile mit „No“ bzw. „Nein“ gekennzeichnet.

CSR-Teile werden abhängig von der Verfügbarkeit und vom Lieferziel am folgenden Geschäftstag geliefert. Für bestimmte Standorte ist eine Lieferung am selben Tag oder innerhalb von vier Stunden gegen einen Aufpreis verfügbar. Wenn Sie Hilfe benötigen, können Sie das Hewlett Packard Enterprise

Support Center anrufen und sich von einem Mitarbeiter per Telefon helfen lassen. Den Materialien von Hewlett Packard Enterprise, die mit einem CSR-Ersatzteil geliefert werden, können Sie entnehmen, ob das defekte Teil an Hewlett Packard Enterprise zurückgeschickt werden muss. Wenn es erforderlich ist, das defekte Teil an Hewlett Packard Enterprise zurückzuschicken, müssen Sie dies innerhalb eines vorgegebenen Zeitraums tun, in der Regel innerhalb von fünf (5) Geschäftstagen. Das defekte Teil muss mit der zugehörigen Dokumentation in der Verpackung zurückgeschickt werden, die im Lieferumfang enthalten ist. Wenn Sie das defekte Teil nicht zurückschicken, kann Hewlett Packard Enterprise Ihnen das Ersatzteil in Rechnung stellen. Im Falle von Customer Self Repair kommt Hewlett Packard Enterprise für alle Kosten für die Lieferung und Rücksendung auf und bestimmt den Kurier-/Frachtdienst.

Weitere Informationen über das Hewlett Packard Enterprise Customer Self Repair Programm erhalten Sie von Ihrem Servicepartner vor Ort. Informationen über das CSR-Programm in Nordamerika finden Sie auf der Hewlett Packard Enterprise Website unter (<http://www.hpe.com/support/selfrepair>).

Parts-only Warranty Service (Garantieservice ausschließlich für Teile)

Ihre Hewlett Packard Enterprise Garantie umfasst möglicherweise einen Parts-only Warranty Service (Garantieservice ausschließlich für Teile). Gemäß den Bestimmungen des Parts-only Warranty Service stellt Hewlett Packard Enterprise Ersatzteile kostenlos zur Verfügung.

Für den Parts-only Warranty Service ist das CSR-Verfahren zwingend vorgegeben. Wenn Sie den Austausch dieser Teile von Hewlett Packard Enterprise vornehmen lassen, werden Ihnen die Anfahrt- und Arbeitskosten für diesen Service berechnet.

Reparaciones del propio cliente

Los productos de Hewlett Packard Enterprise incluyen muchos componentes que el propio usuario puede reemplazar (Customer Self Repair, CSR) para minimizar el tiempo de reparación y ofrecer una mayor flexibilidad a la hora de realizar sustituciones de componentes defectuosos. Si, durante la fase de diagnóstico, Hewlett Packard Enterprise (o los proveedores o socios de servicio de Hewlett Packard Enterprise) identifica que una reparación puede llevarse a cabo mediante el uso de un componente CSR, Hewlett Packard Enterprise le enviará dicho componente directamente para que realice su sustitución. Los componentes CSR se clasifican en dos categorías:

- **Obligatorio**—Componentes cuya reparación por parte del usuario es obligatoria. Si solicita a Hewlett Packard Enterprise que realice la sustitución de estos componentes, tendrá que hacerse cargo de los gastos de desplazamiento y de mano de obra de dicho servicio.
- **Opcional**—Componentes cuya reparación por parte del usuario es opcional. Estos componentes también están diseñados para que puedan ser reparados por el usuario. Sin embargo, si precisa que Hewlett Packard Enterprise realice su sustitución, puede o no conllevar costes adicionales, dependiendo del tipo de servicio de garantía correspondiente al producto.

NOTA: Algunos componentes de Hewlett Packard Enterprise no están diseñados para que puedan ser reparados por el usuario. Para que el usuario haga valer su garantía, Hewlett Packard Enterprise pone como condición que un proveedor de servicios autorizado realice la sustitución de estos componentes. Dichos componentes se identifican con la palabra "No" en el catálogo ilustrado de componentes.

Según la disponibilidad y la situación geográfica, los componentes CSR se enviarán para que lleguen a su destino al siguiente día laborable. Si la situación geográfica lo permite, se puede solicitar la entrega en el mismo día o en cuatro horas con un coste adicional. Si precisa asistencia técnica, puede llamar al Centro de asistencia técnica de Hewlett Packard Enterprise y recibirá ayuda telefónica por parte de un técnico. Con el envío de materiales para la sustitución de componentes CSR, Hewlett Packard Enterprise especificará si los componentes defectuosos deberán devolverse a Hewlett Packard Enterprise. En aquellos casos en los que sea necesario devolver algún componente a Hewlett Packard Enterprise,

deberá hacerlo en el periodo de tiempo especificado, normalmente cinco días laborables. Los componentes defectuosos deberán devolverse con toda la documentación relacionada y con el embalaje de envío. Si no enviara el componente defectuoso requerido, Hewlett Packard Enterprise podrá cobrarle por el de sustitución. En el caso de todas sustituciones que lleve a cabo el cliente, Hewlett Packard Enterprise se hará cargo de todos los gastos de envío y devolución de componentes y escogerá la empresa de transporte que se utilice para dicho servicio.

Para obtener más información acerca del programa de Reparaciones del propio cliente de Hewlett Packard Enterprise, póngase en contacto con su proveedor de servicios local. Si está interesado en el programa para Norteamérica, visite la página web de Hewlett Packard Enterprise CSR (<http://www.hpe.com/support/selfrepair>).

Servicio de garantía exclusivo de componentes

La garantía limitada de Hewlett Packard Enterprise puede que incluya un servicio de garantía exclusivo de componentes. Según las condiciones de este servicio exclusivo de componentes, Hewlett Packard Enterprise le facilitará los componentes de repuesto sin cargo adicional alguno.

Para este servicio de garantía exclusivo de componentes, es obligatoria la sustitución de componentes por parte del usuario (CSR). Si solicita a Hewlett Packard Enterprise que realice la sustitución de estos componentes, tendrá que hacerse cargo de los gastos de desplazamiento y de mano de obra de dicho servicio.

Customer Self Repair

Veel onderdelen in Hewlett Packard Enterprise producten zijn door de klant zelf te repareren, waardoor de reparatieduur tot een minimum beperkt kan blijven en de flexibiliteit in het vervangen van defecte onderdelen groter is. Deze onderdelen worden CSR-onderdelen (Customer Self Repair) genoemd. Als Hewlett Packard Enterprise (of een Hewlett Packard Enterprise Service Partner) bij de diagnose vaststelt dat de reparatie kan worden uitgevoerd met een CSR-onderdeel, verzendt Hewlett Packard Enterprise dat onderdeel rechtstreeks naar u, zodat u het defecte onderdeel daarmee kunt vervangen. Er zijn twee categorieën CSR-onderdelen:

- **Verplicht**—Onderdelen waarvoor reparatie door de klant verplicht is. Als u Hewlett Packard Enterprise verzoekt deze onderdelen voor u te vervangen, worden u voor deze service reiskosten en arbeidsloon in rekening gebracht.
- **Optioneel**—Onderdelen waarvoor reparatie door de klant optioneel is. Ook deze onderdelen zijn ontworpen voor reparatie door de klant. Als u echter Hewlett Packard Enterprise verzoekt deze onderdelen voor u te vervangen, kunnen daarvoor extra kosten in rekening worden gebracht, afhankelijk van het type garantieservice voor het product.

OPMERKING: Sommige Hewlett Packard Enterprise onderdelen zijn niet ontwikkeld voor reparatie door de klant. In verband met de garantievoorwaarden moet het onderdeel door een geautoriseerde Service Partner worden vervangen. Deze onderdelen worden in de geïllustreerde onderdelencatalogus aangemerkt met "Nee".

Afhankelijk van de leverbaarheid en de locatie worden CSR-onderdelen verzonden voor levering op de eerstvolgende werkdag. Levering op dezelfde dag of binnen vier uur kan tegen meerkosten worden aangeboden, indien dit mogelijk is gezien de locatie. Indien assistentie is gewenst, belt u het Hewlett Packard Enterprise Support Center om via de telefoon ondersteuning van een technicus te ontvangen. Hewlett Packard Enterprise vermeldt in de documentatie bij het vervangende CSR-onderdeel of het defecte onderdeel aan Hewlett Packard Enterprise moet worden geretourneerd. Als het defecte onderdeel aan Hewlett Packard Enterprise moet worden teruggezonden, moet u het defecte onderdeel binnen een bepaalde periode, gewoonlijk vijf (5) werkdagen, retourneren aan Hewlett Packard Enterprise. Het defecte onderdeel moet met de bijbehorende documentatie worden geretourneerd in het meegeleverde verpakkingsmateriaal. Als u het defecte onderdeel niet terugzendt, kan Hewlett Packard

Enterprise u voor het vervangende onderdeel kosten in rekening brengen. Bij reparatie door de klant betaalt Hewlett Packard Enterprise alle verzendkosten voor het vervangende en geretourneerde onderdeel en kiest Hewlett Packard Enterprise zelf welke koerier/transportonderneming hiervoor wordt gebruikt.

Neem contact op met een Service Partner voor meer informatie over het Customer Self Repair programma van Hewlett Packard Enterprise. Informatie over Service Partners vindt u op de Hewlett Packard Enterprise website (<http://www.hpe.com/support/selfrepair>).

Garantieservice "Parts Only"

Het is mogelijk dat de Hewlett Packard Enterprise garantie alleen de garantieservice "Parts Only" omvat. Volgens de bepalingen van de Parts Only garantieservice zal Hewlett Packard Enterprise kosteloos vervangende onderdelen ter beschikking stellen.

Voor de Parts Only garantieservice is vervanging door CSR-onderdelen verplicht. Als u Hewlett Packard Enterprise verzoekt deze onderdelen voor u te vervangen, worden u voor deze service reiskosten en arbeidsloon in rekening gebracht

Reparo feito pelo cliente

Os produtos da Hewlett Packard Enterprise são projetados com muitas peças para reparo feito pelo cliente (CSR) de modo a minimizar o tempo de reparo e permitir maior flexibilidade na substituição de peças com defeito. Se, durante o período de diagnóstico, a Hewlett Packard Enterprise (ou fornecedores/parceiros da Hewlett Packard Enterprise) concluir que o reparo pode ser efetuado pelo uso de uma peça CSR, a Hewlett Packard Enterprise enviará a peça diretamente ao cliente. Há duas categorias de peças CSR:

- **Obrigatória**—Peças cujo reparo feito pelo cliente é obrigatório. Se desejar que a Hewlett Packard Enterprise substitua essas peças, serão cobradas as despesas de transporte e mão-de-obra do serviço.
- **Opcional**—Peças cujo reparo feito pelo cliente é opcional. Essas peças também são projetadas para o reparo feito pelo cliente. No entanto, se desejar que a Hewlett Packard Enterprise as substitua, pode haver ou não a cobrança de taxa adicional, dependendo do tipo de serviço de garantia destinado ao produto.

OBSERVAÇÃO: Algumas peças da Hewlett Packard Enterprise não são projetadas para o reparo feito pelo cliente. A fim de cumprir a garantia do cliente, a Hewlett Packard Enterprise exige que um técnico autorizado substitua a peça. Essas peças estão identificadas com a marca "No" (Não), no catálogo de peças ilustrado.

Conforme a disponibilidade e o local geográfico, as peças CSR serão enviadas no primeiro dia útil após o pedido. Onde as condições geográficas permitirem, a entrega no mesmo dia ou em quatro horas pode ser feita mediante uma taxa adicional. Se precisar de auxílio, entre em contato com o Centro de suporte técnico da Hewlett Packard Enterprise para que um técnico o ajude por telefone. A Hewlett Packard Enterprise especifica nos materiais fornecidos com a peça CSR de reposição se a peça com defeito deve ser devolvida à Hewlett Packard Enterprise. Nos casos em que isso for necessário, é preciso enviar a peça com defeito à Hewlett Packard Enterprise, você deverá enviar a peça com defeito de volta para a Hewlett Packard Enterprise dentro do período de tempo definido, normalmente em 5 (cinco) dias úteis. A peça com defeito deve ser enviada com a documentação correspondente no material de transporte fornecido. Caso não o faça, a Hewlett Packard Enterprise poderá cobrar a reposição. Para as peças de reparo feito pelo cliente, a Hewlett Packard Enterprise paga todas as despesas de transporte e de devolução da peça e determina a transportadora/serviço postal a ser utilizado.

Para obter mais informações sobre o programa de reparo feito pelo cliente da Hewlett Packard Enterprise, entre em contato com o fornecedor de serviços local. Para o programa norte-americano, visite o site da Hewlett Packard Enterprise (<http://www.hpe.com/support/selfrepair>).

Serviço de garantia apenas para peças

A garantia limitada da Hewlett Packard Enterprise pode incluir um serviço de garantia apenas para peças. Segundo os termos do serviço de garantia apenas para peças, a Hewlett Packard Enterprise fornece as peças de reposição sem cobrar nenhuma taxa.

No caso desse serviço, a substituição de peças CSR é obrigatória. Se desejar que a Hewlett Packard Enterprise substitua essas peças, serão cobradas as despesas de transporte e mão-de-obra do serviço.

カスタマーセルフリペア

修理時間を短縮し、故障部品の交換における高い柔軟性を確保するために、Hewlett Packard Enterprise製品には多数のカスタマーセルフリペア（CSR）部品があります。診断の際に、CSR部品を使用すれば修理ができるかとHewlett Packard Enterprise（Hewlett Packard EnterpriseまたはHewlett Packard Enterprise正規保守代理店）が判断した場合、Hewlett Packard Enterpriseはその部品を直接、お客様に発送し、お客様に交換していただきます。CSR部品には以下の2種類があります。

- **必須** - カスタマーセルフリペアが必須の部品。当該部品について、もしもお客様がHewlett Packard Enterpriseに交換作業を依頼される場合には、その修理サービスに関する交通費および人件費がお客様に請求されます。
- **任意** - カスタマーセルフリペアが任意である部品。この部品もカスタマーセルフリペア用です。当該部品について、もしもお客様がHewlett Packard Enterpriseに交換作業を依頼される場合には、お買い上げの製品に適用される保証サービス内容の範囲内においては、別途費用を負担していただくことなく保証サービスを受けることができます。

注：Hewlett Packard Enterprise製品の一部の部品は、カスタマーセルフリペアの対象外です。製品の保証を継続するためには、Hewlett Packard EnterpriseまたはHewlett Packard Enterprise正規保守代理店による交換作業が必須となります。部品カタログには、当該部品がカスタマーセルフリペア除外品である旨が記載されています。

部品供給が可能な場合、地域によっては、CSR部品を翌営業日に届くように発送します。また、地域によっては、追加費用を負担いただくことにより同日または4時間以内に届くように発送することも可能な場合があります。サポートが必要なときは、Hewlett Packard Enterpriseサポートセンターに電話していただければ、技術者が電話でアドバイスします。交換用のCSR部品または同梱物には、故障部品をHewlett Packard Enterpriseに返送する必要があるかどうかが表示されています。故障部品をHewlett Packard Enterpriseに返送する必要がある場合は、指定期限内（通常は5営業日以内）に故障部品をHewlett Packard Enterpriseに返送してください。故障部品を返送する場合は、届いた時の梱包箱に関連書類とともにに入れてください。故障部品を返送しない場合、Hewlett Packard Enterpriseから部品費用が請求されます。カスタマーセルフリペアの際には、Hewlett Packard Enterpriseは送料および部品返送費を全額負担し、使用する宅配便会社や運送会社を指定します。

部品のみ保証サービス

Hewlett Packard Enterprise保証サービスには、部品のみ保証サービスが適用される場合があります。このサービスでは、交換部品は無償で提供されます。

部品のみ保証サービスにおいては、CSR部品をお客様により交換作業していただくことが必須となります。当該部品について、もしもお客様がHewlett Packard Enterpriseに交換作業を依頼される場合には、その修理サービスに関する交通費および人件費がお客様のご負担となります。

客户自行维修

Hewlett Packard Enterprise 产品提供许多客户自行维修 (CSR) 部件，以尽可能缩短维修时间和在更换缺陷部件方面提供更大的灵活性。如果在诊断期间 Hewlett Packard Enterprise (或 Hewlett Packard Enterprise 服务提供商或服务合作伙伴) 确定可以通过使用 CSR 部件完成维修，Hewlett Packard Enterprise 将直接把该部件发送给您进行更换。有两类 CSR 部件：

- **强制性的** — 要求客户必须自行维修的部件。如果您请求 Hewlett Packard Enterprise 更换这些部件，则必须为该服务支付差旅费和人工费用。
- **可选的** — 客户可以选择是否自行维修的部件。这些部件也是为客户自行维修设计的。不过，如果您要求 Hewlett Packard Enterprise 为您更换这些部件，则根据为您的产品指定的保修服务类型，Hewlett Packard Enterprise 可能收取或不再收取任何附加费用。

注：某些 Hewlett Packard Enterprise 部件的设计并未考虑客户自行维修。为了满足客户保修的需要，Hewlett Packard Enterprise 要求授权服务提供商更换相关部件。这些部件在部件图解目录中标记为“否”。

CSR 部件将在下一个工作日发运（取决于备货情况和允许的地理范围）。在允许的地理范围内，可在当天或四小时内发运，但要收取额外费用。如果需要帮助，您可以致电 Hewlett Packard Enterprise 技术支持中心，将会有技术人员通过电话为您提供帮助。Hewlett Packard Enterprise 会在随更换的 CSR 部件发运的材料中指明是否必须将有缺陷的部件返还给 Hewlett Packard Enterprise。如果要求您将有缺陷的部件返还给 Hewlett Packard Enterprise，那么您必须在规定的期限内（通常是五 (5) 个工作日）将缺陷部件发给 Hewlett Packard Enterprise。有缺陷的部件必须随所提供的发运材料中的相关文件一起返还。如果未能送还有缺陷的部件，Hewlett Packard Enterprise 可能会要求您支付更换费用。客户自行维修时，Hewlett Packard Enterprise 将承担所有相关运输和部件返回费用，并指定快递商/承运商。

有关 Hewlett Packard Enterprise 客户自行维修计划的详细信息，请与您当地的服务提供商联系。有关北美地区的计划，请访问 Hewlett Packard Enterprise 网站 (<http://www.hpe.com/support/selfrepair>)。

仅部件保修服务

您的 Hewlett Packard Enterprise 有限保修服务可能涉及仅部件保修服务。根据仅部件保修服务条款的规定，Hewlett Packard Enterprise 将免费提供更换的部件。

仅部件保修服务要求进行 CSR 部件更换。如果您请求 Hewlett Packard Enterprise 更换这些部件，则必须为该服务支付差旅费和人工费用。

客戶自行維修

Hewlett Packard Enterprise 產品設計了許多「客戶自行維修」(CSR) 的零件以減少維修時間，並且使得更換瑕疵零件時能有更大的彈性。如果在診斷期間，Hewlett Packard Enterprise (或 Hewlett Packard Enterprise 服務供應商或維修夥伴) 辨認出此項維修工作可以藉由使用 CSR 零件來完成，則 Hewlett Packard Enterprise 將直接寄送該零件給您作更換。CSR 零件分為兩種類別：

- **強制的** — 客戶自行維修所使用的零件是強制性的。如果您要求 Hewlett Packard Enterprise 更換這些零件，Hewlett Packard Enterprise 將會向您收取此服務所需的外出費用與勞動成本。
- **選購的** — 客戶自行維修所使用的零件是選購的。這些零件也設計用於客戶自行維修之用。不過，如果您要求 Hewlett Packard Enterprise 為您更換，則可能需要也可能不需要負擔額外的費用，端視針對此產品指定的保固服務類型而定。

備註：某些 Hewlett Packard Enterprise 零件沒有消費者可自行維修的設計。為符合客戶保固，Hewlett Packard Enterprise 需要授權的服務供應商更換零件。這些零件在圖示的零件目錄中，被標示為「否」。

基於材料取得及環境允許的情況下，CSR 零件將於下一個工作日以快遞寄送。在環境的允許下當天或四小時內送達，則可能需要額外的費用。若您需要協助，可致電 Hewlett Packard Enterprise 支援中心，會有一位技術人員透過電話來協助您。不論損壞的零件是否必須退回，Hewlett Packard Enterprise 皆會在與 CSR 替換零件一起運送的材料中註明。若要將損壞的零件退回 Hewlett Packard Enterprise，您必須在指定的一段時間內 (通常為五 (5) 個工作天)，將損壞的零件寄回 Hewlett Packard Enterprise。損壞的零件必須與寄送資料中隨附的相關技術文件一併退還。如果無法退還損壞的零件，Hewlett Packard Enterprise 可能要向您收取替換費用。針對客戶自行維修情形，Hewlett Packard Enterprise 將負責所有運費及零件退還費用，並指定使用何家快遞/貨運公司。

如需 Hewlett Packard Enterprise 的 CSR 方案詳細資訊，請連絡您當地的服務供應商。至於北美方案，請參閱 Hewlett Packard Enterprise 的 CSR 網站repair (<http://www.hpe.com/support/selfrepair>)。

僅限零件的保固服務

您的「Hewlett Packard Enterprise 有限保固」可能包含僅限零件的保固服務。在僅限零件的保固服務情況下，Hewlett Packard Enterprise 將免費提供替換零件。

針對僅限零件的保固服務，CSR 零件替換是強制性的。如果您要求 Hewlett Packard Enterprise 更換這些零件，Hewlett Packard Enterprise 將會向您收取此服務所需的外出費用與勞動成本。

고객 셀프 수리

Hewlett Packard Enterprise 제품은 수리 시간을 최소화하고 결함이 있는 부품 교체 시 더욱 용동성을 발휘할 수 있도록 하기 위해 고객 셀프 수리(CSR) 부품을 다량 사용하여 설계되었습니다. 진단 기간 동안 Hewlett Packard Enterprise(또는 Hewlett Packard Enterprise 서비스 공급업체 또는 서비스 협력업체)에서 CSR 부품을 사용하여 수리가 가능하다고 판단되면 Hewlett Packard Enterprise는 해당 부품을 바로 사용자에게 보내어 사용자가 교체할 수 있도록 합니다. CSR 부품에는 두 가지 종류가 있습니다.

- 필수 - 고객 셀프 수리가 의무 사항인 필수 부품. 사용자가 Hewlett Packard Enterprise에 이 부품의 교체를 요청할 경우 이 서비스에 대한 출장비 및 작업비가 청구됩니다.
- 선택 사항 - 고객 셀프 수리가 선택 사항인 부품. 이 부품들도 고객 셀프 수리가 가능하도록 설계되었습니다. 하지만 사용자가 Hewlett Packard Enterprise에 이 부품의 교체를 요청할 경우 사용자가 구입한 제품에 해당하는 보증 서비스 유형에 따라 추가 비용 없이 교체가 가능할 수 있습니다.

참고: 일부 Hewlett Packard Enterprise 부품은 고객 셀프 수리가 불가능하도록 설계되었습니다. Hewlett Packard Enterprise는 만족스러운 고객 보증을 위해 공인 서비스 제공업체를 통해 부품을 교체하도록 하고 있습니다. 이러한 부품들은 Illustrated Parts Catalog에 “No”라고 표시되어 있습니다.

CSR 부품은 재고 상태와 지리적 조건이 허용하는 경우 다음 영업일 납품이 가능하도록 배송이 이루어집니다. 지리적 조건이 허용하는 경우 추가 비용이 청구되는 조건으로 당일 또는 4시간 배송이 가능할 수도 있습니다. 도움이 필요하시면 Hewlett Packard Enterprise Support Center로 전화하십시오. 전문 기술자가 전화로 도움을 줄 것입니다. Hewlett Packard Enterprise는 결함이 발생한 부품을 Hewlett Packard Enterprise로 반환해야 하는지 여부를 CSR 교체 부품과 함께 배송된 자료에 지정합니다. 결함이 발생한 부품을 Hewlett Packard Enterprise로 반환해야 하는 경우에는 지정된 기간 내(통상 영업일 기준 5일)에 Hewlett Packard Enterprise로 반환해야 합니다. 이때 결함이 발생한 부품은 제공된 포장 재료에 넣어 관련 설명서와 함께 반환해야 합니다. 결함이 발생한 부품을 반환하지 않는 경우 Hewlett Packard Enterprise가 교체 부품에 대해 비용을 청구할 수 있습니다. 고객 셀프 수리의 경우, Hewlett Packard Enterprise는 모든 운송 및 부품 반환 비용을 부담하며 이용할 운송업체 및 택배 서비스를 결정합니다.

Hewlett Packard Enterprise CSR 프로그램에 대한 자세한 내용은 가까운 서비스 제공업체에 문의하십시오. 북미 지역의 프로그램에 대해서는 Hewlett Packard Enterprise CSR 웹 사이트(<http://www.hpe.com/support/selfrepair>)를 참조하십시오.

부품 제공 보증 서비스

Hewlett Packard Enterprise 제한 보증에는 부품 제공 보증 서비스가 포함될 수 있습니다. 이러한 경우 Hewlett Packard Enterprise는 부품 제공 보증 서비스의 조건에 따라 교체 부품만을 무료로 제공합니다.

부품 제공 보증 서비스 제공 시 CSR 부품 교체는 의무 사항입니다. 사용자가 Hewlett Packard Enterprise에 이 부품의 교체를 요청할 경우 이 서비스에 대한 출장비 및 작업비가 청구됩니다.

Illustrated parts catalog

Mechanical components

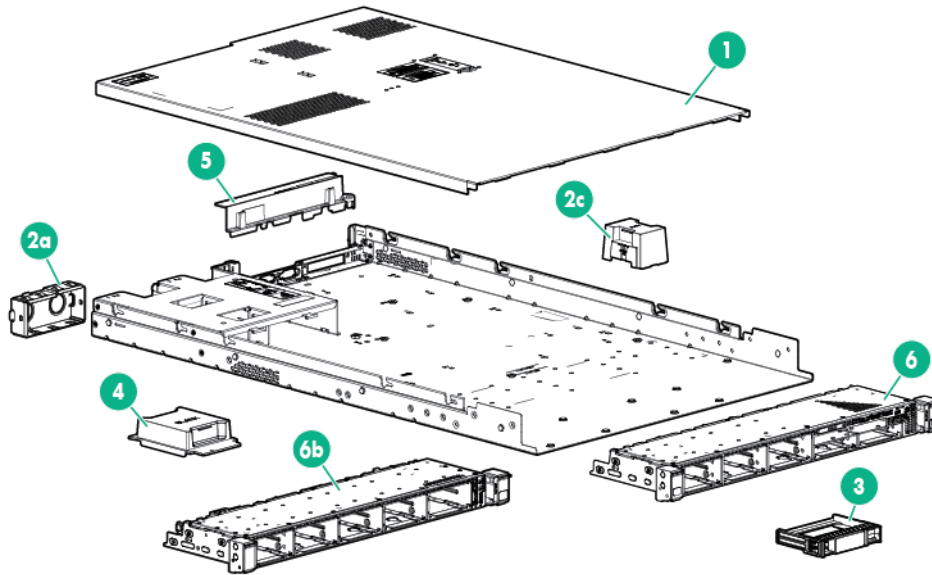

Item	Description	Spare part number	Customer self repair (on page 5)
1	Access panel	—	—
	a) Caged heatsink access panel	671351-001	Mandatory ¹
	b) Screw-down heatsink access panel*	743499-001	Mandatory ¹
2	Miscellaneous hardware kit	671354-001	Mandatory ¹
	a) Power supply blank	—	—
	b) Power cord clip*	—	—
	c) Fan blank	—	—
3	Hard drive blank	—	—
	a) SFF hard drive blank, 6.35 cm (2.5 in)	670033-001	Mandatory ¹
	b) LFF hard drive blank, 8.89 cm (3.5 in)*	675039-001	Mandatory ¹
4	Processor blank	—	—
	a) Caged processor blank	675061-001	Mandatory ¹
	b) Screw-down processor blank*	743136-001	Mandatory ¹
5	Power supply air baffle	675037-001	Mandatory ¹
6	Hard drive cage	—	—
	a) 8 SFF hard drive cage* **	667868-001	Mandatory ¹

Item	Description	Spare part number	Customer self repair (on page 5)
	b) 10 SFF hard drive cage**	692479-001	Mandatory ¹
	c) 4 LFF hard drive cage* **	667869-001	Mandatory ¹
	Rack mounting hardware	—	—
7	Rack mounting hardware kit*	—	—
	a) 8 or 10 SFF ball bearing kit	675042-001	Mandatory ¹
	b) 4 LFF ball bearing kit	675041-001	Mandatory ¹
	c) Friction rail kit	675040-001	Mandatory ¹
	d) SFF easy install rail kit	744111-001	Mandatory ¹
	e) LFF easy install rail kit	744112-001	Mandatory ¹
8	Cable management arm*	—	—
	a) Cable management arm	675043-001	Mandatory ¹
	b) Cable management arm, easy install	744113-001	Mandatory ¹

*Not shown

**If a replacement 24-pin SFF cable (spare part number 667878-001) or 20-pin SFF cable (spare part number 667877-001) is needed, the cables ship with the 8 SFF hard drive cage (spare part number 667868-001). If a replacement cable is needed for the 10 SFF drive cage, the cable ships with the 10 SFF drive cage (spare part number 692479-001).

¹Mandatory—Parts for which customer self repair is mandatory. If you request Hewlett Packard Enterprise to replace these parts, you will be charged for the travel and labor costs of this service.

²Optional—Parts for which customer self repair is optional. These parts are also designed for customer self repair. If, however, you require that Hewlett Packard Enterprise replace them for you, there may or may not be additional charges, depending on the type of warranty service designated for your product.

³No—Some Hewlett Packard Enterprise parts are not designed for customer self repair. In order to satisfy the customer warranty, Hewlett Packard Enterprise requires that an authorized service provider replace the part. These parts are identified as "No" in the Illustrated Parts Catalog.

¹Obligatoire—Pièces pour lesquelles le client doit procéder lui-même aux réparations. Si vous demandez à Hewlett Packard Enterprise de procéder au remplacement de ces pièces, les frais de transport et de main d'œuvre pour ce service vous seront facturés.

²Facultatif—Pièces pour lesquelles une réparation par le client est facultative. Ces pièces sont également conçues pour que le client puisse procéder lui-même aux réparations. Cependant, les frais supplémentaires engendrés par le remplacement de ces pièces par Hewlett Packard Enterprise dépendent du type de service de garantie désigné pour votre produit.

³Non—Certaines pièces Hewlett Packard Enterprise ne sont pas conçues pour être remplacées par le client. Afin de se conformer aux exigences de la garantie la garantie du client, Hewlett Packard Enterprise demande à un fournisseur de services agréé de procéder au remplacement de la pièce. Ces pièces sont signalées par le mot « Non » dans le Catalogue de pièces illustré.

¹Obbligatorio—Parti per le quali il cliente è tenuto a effettuare autonomamente la riparazione. Se si richiede l'intervento di Hewlett Packard Enterprise per la sostituzione di queste parti, al cliente verranno addebitate le spese di viaggio e manodopera dell'operazione.

²Facoltativo—Parti per le quali la riparazione in autonomia da parte del cliente è facoltativa. Queste parti sono progettate per consentire anche la riparazione da parte del cliente. Tuttavia, se il cliente richiede l'intervento di Hewlett Packard Enterprise per la sostituzione, potrebbero essere addebitate spese aggiuntive a seconda del tipo di garanzia in assistenza previsto per il prodotto.

³No—Alcune parti Hewlett Packard Enterprise non sono progettate la riparazione in autonomia da parte del cliente. In base a quanto previsto dalla garanzia per il cliente, Hewlett Packard Enterprise richiede l'intervento di un tecnico autorizzato per la sostituzione della parte. Queste parti sono contrassegnate con "No" nel catalogo parti illustrato.

¹Zwingend—Teile, für die das Customer Self Repair-Verfahren zwingend vorgegeben ist. Wenn Sie den Austausch dieser Teile von Hewlett Packard Enterprise vornehmen lassen, werden Ihnen die Anfahrt- und Arbeitskosten für diesen Service berechnet.

²Optional—Teile, für die das Customer Self Repair-Verfahren optional ist. Diese Teile sind auch für Customer Self Repair ausgelegt. Wenn Sie jedoch den Austausch dieser Teile von Hewlett Packard Enterprise vornehmen lassen möchten, können bei diesem Service je nach den für Ihr Produkt vorgesehenen Garantiebedingungen zusätzliche Kosten anfallen.

³Nein—Einige Hewlett Packard Enterprise Teile sind nicht für Customer Self Repair ausgelegt. Um den Garantieanspruch des Kunden zu erfüllen, muss das Teil von einem Hewlett Packard Enterprise Servicepartner ersetzt werden. Im illustrierten Teilekatalog sind diese Teile mit „No“ bzw. „Nein“ gekennzeichnet.

¹Obligatorio—Componentes cuya reparación por parte del usuario es obligatoria. Si solicita a Hewlett Packard Enterprise que realice la sustitución de estos componentes, tendrá que hacerse cargo de los gastos de desplazamiento y de mano de obra de dicho servicio.

²Opcional—Componentes cuya reparación por parte del usuario es opcional. Estos componentes también están diseñados para que puedan ser reparados por el usuario. Sin embargo, si precisa que Hewlett Packard Enterprise realice su sustitución, puede o no conllevar costes adicionales, dependiendo del tipo de servicio de garantía correspondiente al producto.

³No—Algunos componentes de Hewlett Packard Enterprise no están diseñados para que puedan ser reparados por el usuario. Para que el usuario haga valer su garantía, Hewlett Packard Enterprise pone como condición que un proveedor de servicios autorizado realice la sustitución de estos componentes. Dichos componentes se identifican con la palabra "No" en el catálogo ilustrado de componentes.

¹Verplicht—Onderdelen die de klant zelf moet vervangen. Als u Hewlett Packard Enterprise vraagt deze onderdelen te vervangen, worden er reis- en arbeidskosten voor deze service in rekening gebracht.

²Optioneel—Onderdelen die de klant zelf kan vervangen. Deze onderdelen zijn ook ontworpen om door de klant zelf te worden vervangen. Als u Hewlett Packard Enterprise verzoekt om deze te vervangen, kan het zijn dat hiervoor extra kosten in rekening worden gebracht, afhankelijk van het soort garantie dat op uw product van toepassing is.

³Geen—Sommige onderdelen van Hewlett Packard Enterprise zijn niet ontworpen om door de klant zelf te worden vervangen. Om te voldoen aan de garantievoorwaarden eist Hewlett Packard Enterprise dat een geautoriseerde serviceverlener het onderdeel vervangt. Deze onderdelen worden aangeduid met 'Geen' in de geïllustreerde onderdelencatalogus.

¹Obrigatório—Peças cujo reparo feito pelo cliente é obrigatório. Se desejar que a Hewlett Packard Enterprise substitua essas peças, serão cobradas as despesas de transporte e mão-de-obra do serviço.

²Opcional—Peças cujo reparo feito pelo cliente é opcional. Essas peças também são projetadas para o reparo feito pelo cliente. No entanto, se desejar que a Hewlett Packard Enterprise as substitua, pode haver ou não a cobrança de taxa adicional, dependendo do tipo de serviço de garantia destinado ao produto.

³Não—Algumas peças da Hewlett Packard Enterprise não são projetadas para o reparo feito pelo cliente. A fim de cumprir a garantia do cliente, a Hewlett Packard Enterprise exige que um técnico autorizado substitua a peça. Essas peças estão identificadas com a marca "No" (Não), no catálogo de peças ilustrado.

¹Mandatory : 必須 — カスタマーセルフリペアが必須の部品。当該部品について、もしもお客様がHewlett Packard Enterpriseに交換作業を依頼される場合には、その修理サービスに関する交通費および人件費がお客様に請求されます。

²Optional : 任意 — カスタマーセルフリペアが任意である部品。この部品もカスタマーセルフリペア用です。当該部品について、もしもお客様がHewlett Packard Enterpriseに交換作業を依頼される場合には、お買い上げの製品に適用される保証サービス内容の範囲内においては、別途費用を負担していただくことなく保証サービスを受けることができます。

³No : 除外 — Hewlett Packard Enterprise製品の一部の部品は、カスタマーセルフリペアの対象外です。製品の保証を継続するためには、Hewlett Packard EnterpriseまたはHewlett Packard Enterprise正規保守代理店による交換作業が必須となります。部品カタログには、当該部品がカスタマーセルフリペア除外品である旨が記載されています。

¹Mandatory — 客户必须自行维修的部件。如果您请求 Hewlett Packard Enterprise 更换这些部件，则必须为该服务支付差旅费和人工费用。

²Optional — 客户可以选择是否自行维修的部件。这些部件也是为客户自行维修设计的。不过，如果您要求 Hewlett Packard Enterprise 为您更换这些部件，则根据为您的产品指定的保修服务类型，Hewlett Packard Enterprise 可能收取或不再收取任何附加费用。

³No — 某些 Hewlett Packard Enterprise 部件的设计并未考虑客户自行维修。为了满足客户保修的需要，Hewlett Packard Enterprise 要求授权服务提供商更换相关部件。这些部件在部件图解目录中标记为“否”。

¹Mandatory — 客户自行维修所使用的零件是强制性的。如果您要求 Hewlett Packard Enterprise 更换这些零件，Hewlett Packard Enterprise 将会向您收取此服务所需的外出费用与劳动成本。

²Optional — 客户自行维修所使用的零件是可选的。这些零件也设计用于客户自行维修之用。不过，如果您要求 Hewlett Packard Enterprise 为您更换，则可能需要也可能不需要负担额外的费用，端视针对此产品指定的保修服务类型而定。

³No — 某些 Hewlett Packard Enterprise 零件没有消费者可自行维修的设计。为符合客户保修，Hewlett Packard Enterprise 需要授权的服务提供商更换零件。这些零件在图示的零件目录中，被标示为「否」。

¹Mandatory — 고객 셀프 수리가 의무 사항인 필수 부품. 사용자가 Hewlett Packard Enterprise에 이 부품의 교체를 요청할 경우 해당 서비스에 대한 출장비 및 작업비가 청구됩니다.

²Optional — 고객 셀프 수리가 선택 사항인 부품. 이러한 부품들도 고객 셀프 수리가 가능하도록 설계되었습니다. 하지만 사용자가 Hewlett Packard Enterprise에 이러한 부품의 교체를 요청할 경우 사용자가 구입한 제품에 해당하는 보증 서비스 유형에 따라 추가 비용 없이 교체가 가능할 수 있습니다.

³No — 일부 Hewlett Packard Enterprise 부품은 고객 셀프 수리가 불가능하도록 설계되었습니다. Hewlett Packard Enterprise는 만족스러운 고객 보증을 위해 공인 서비스 제공업체를 통해 부품을 교체하도록 요구하고 있습니다. 이러한 부품들은 Illustrated Parts Catalog에 "No"라고 표시되어 있습니다.

System components

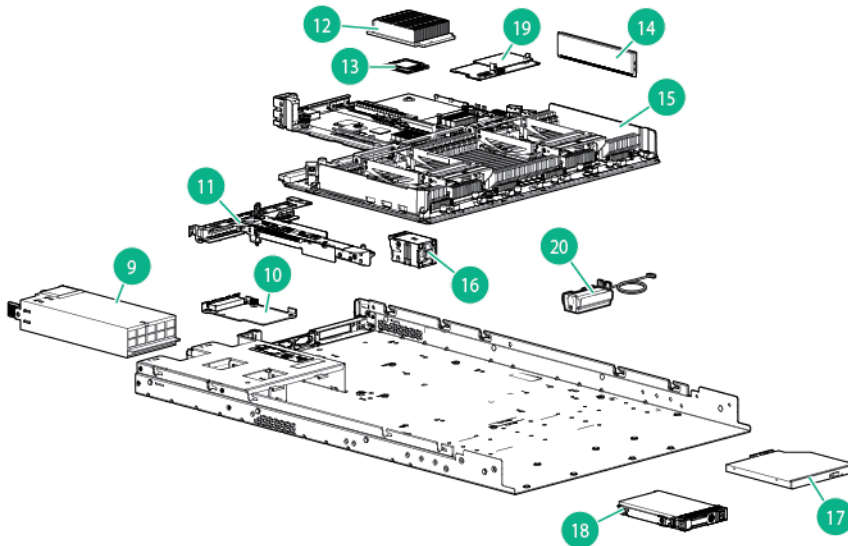

Item	Description	Spare part number	Customer self repair (on page 5)
9	Hot-plug power supplies	—	—
	a) 460 W, 92%	511777-001	Mandatory ¹
	b) 460 W, Platinum Plus, 94%*	660184-001	Mandatory ¹
	c) 500 W, 277 V AC, 94%*	638549-001	Mandatory ¹

Item	Description	Spare part number	Customer self repair (on page 5)
	d) 750 W, 277 V AC, 94%*	674890-001	Mandatory ¹
	e) 750 W, Titanium 96%*	700287-001	Mandatory ¹
	f) 750 W, 92%*	511778-001	Mandatory ¹
	g) 750 W, Platinum Plus, 94%*	660183-001	Mandatory ¹
	h) 750 W 48V DC, 92%*	639173-001	Mandatory ¹
	i) 1200 W, Platinum Plus, 94%*	660185-001	Mandatory ¹
10	HPE FlexibleLOM for Racks	—	—
	a) 1-Gb, 4 ports	634025-001	Optional ²
	b) 10-Gb, 2 ports*	649869-001	Optional ²
	c) 10-Gb, 2 ports*	634026-001	Optional ²
	d) 10-Gb/40-Gb, 2 ports*	656090-001	Optional ²
	e) 10-Gb/40-Gb, 2 ports*	656091-001	Optional ²
11	PCI riser cage	671352-001	Mandatory ¹
12	Heatsink	—	—
	a) Standard latch, with thermal grease	667880-001	Optional ²
	b) High-end latch, with thermal grease*	667881-001	Optional ²
	c) Standard screw-down, with thermal grease*	735506-001	Optional ²
	d) High-end screw down, with thermal grease*	735507-001	Optional ²
13	Processor	—	—
	a) 1.80-GHz Intel Xeon processor E5-2603, 80W ** †	670533-001	Optional ²
	b) 1.80-GHz Intel Xeon processor E5-2603v2, 80W* ** †	730243-001	Optional ²
	c) 2.40-GHz Intel Xeon processor E5-2609, 80W* ** †	670530-001	Optional ²
	d) 2.5-GHz Intel Xeon processor E5-2609v2, 80W* ** †	730242-001	Optional ²
	e) 2.00-GHz Intel Xeon processor E5-2620, 95W* ** †	670529-001	Optional ²
	f) 2.1-GHz Intel Xeon processor E5-2620v2, 80W* ** †	730241-001	Optional ²
	g) 2.00-GHz Intel Xeon processor E5-2630L, 60W* ** †	670535-001	Optional ²
	h) 2.40-GHz Intel Xeon processor E5-2630Lv2, 60W* ** †	730244-001	Optional ²
	i) 2.30-GHz Intel Xeon processor E5-2630, 95W* ** †	670528-001	Optional ²
	j) 2.6-GHz Intel Xeon processor E5-2630v2, 80W* ** †	730240-001	Optional ²
	k) 3.00-GHz Intel Xeon processor E5-2637, 80W* ** †	670539-001	Optional ²
	l) 3.5-GHz Intel Xeon processor E5-2637v2, 130W* ** †	730249-001	Optional ²
	m) 2.50-GHz Intel Xeon processor E5-2640, 95W* ** †	670527-001	Optional ²
	n) 2.0-GHz Intel Xeon processor E5-2640v2, 95W* ** †	730239-001	Optional ²
	o) 3.30-GHz Intel Xeon processor E5-2643, 130W* ** †	670538-001	Optional ²

Item	Description	Spare part number	Customer self repair (on page 5)
	p) 3.3-GHz Intel Xeon processor E5-2643v2, 130W* ** †	730248-001	Optional ²
	q) 1.80-GHz Intel Xeon processor E5-2650L, 70W* ** †	670534-001	Optional ²
	r) 1.7-GHz Intel Xeon processor E5-2650Lv2, 70W* ** †	730250-001	Optional ²
	s) 2.00-GHz Intel Xeon processor E5-2650, 95W* ** †	670526-001	Optional ²
	t) 2.6-GHz Intel Xeon processor E5-2650v2, 95W* ** †	730238-001	Optional ²
	u) 2.20-GHz Intel Xeon processor E5-2660, 95W* ** †	670525-001	Optional ²
	v) 2.2-GHz Intel Xeon processor E5-2660v2, 95W* ** †	730237-001	Optional ²
	w) 2.40-GHz Intel Xeon processor E5-2665, 115W* ** †	670524-001	Optional ²
	x) 2.90-GHz Intel Xeon processor E5-2667, 130W* ** †	670537-001	Optional ²
	y) 3.0-GHz Intel Xeon processor E5-2667v2, 130W* ** †	730247-001	Optional ²
	z) 2.60-GHz Intel Xeon processor E5-2670, 115W* ** †	670523-001	Optional ²
	aa) 2.5-GHz Intel Xeon processor E5-2670v2, 115W* ** †	730236-001	Optional ²
	bb) 2.70-GHz Intel Xeon processor E5-2680, 130W* ** †	670522-001	Optional ²
	cc) 2.8-GHz Intel Xeon processor E5-2680v2, 115W* ** †	730235-001	Optional ²
	dd) 3.90-GHz Intel Xeon processor E5-2690, 135W* ** †	670521-001	Optional ²
	ee) 3.0-GHz Intel Xeon processor E5-2690v2, 130W* ** †	730234-001	Optional ²
	Memory	—	—
14	DIMM	—	—
	a) 2-GB, PC3L-10600E-9, single-rank x8	664694-001	Mandatory ¹
	b) 2-GB, PC3L-12800E-11, single-rank x8*	715279-001	Mandatory ¹
	c) 2-GB, PC3-14900E-13, single-rank x8*	715269-001	Mandatory ¹
	d) 4-GB, PC3-14900E-13, single-rank x8*	715270-001	Mandatory ¹
	e) 4-GB, PC3-14900R-13, dual-rank x4*	715272-001	Mandatory ¹
	f) 4-GB, PC3-12800R-11, single-rank x4*	664689-001	Mandatory ¹
	g) 4-GB, PC3L-12800R-11, dual-rank x4*	715282-001	Mandatory ¹
	h) 4-GB, PC3L-12800E-11, single rank x8*	715280-001	Mandatory ¹
	i) 4-GB, PC3L-10600R-9, single-rank x4*	664688-001	Mandatory ¹
	j) 4-GB, PC3L-10600E-9, dual-rank x8*	664695-001	Mandatory ¹
	k) 8-GB, PC3-14900E-13, dual-rank x8*	715271-001	Mandatory ¹
	l) 8-GB, PC3L-12800E-11, dual-rank x8*	715281-001	Mandatory ¹
	m) 8-GB, PC3L-12800R-11, dual-rank x4*	715283-001	Mandatory ¹
	n) 8-GB, PC3-14900R-13, dual-rank x4*	715273-001	Mandatory ¹
	o) 8-GB, PC3-14900R-13, quad-rank x4*	735303-001	Mandatory ¹

Item	Description	Spare part number	Customer self repair (on page 5)
	p) 8-GB, PC3L-12800R-11, quad-rank x4*	735302-001	Mandatory ¹
	q) 8-GB, PC3-12800R-1, single-rank x4*	664691-001	Mandatory ¹
	r) 8-GB, PC3L-10600R-9, dual-rank x4*	664690-001	Mandatory ¹
	s) 8-GB, PC3L-10600E-9, dual-rank x8*	664696-001	Mandatory ¹
	t) 16-GB, PC3-12800R-11, dual-rank x4*	684031-001	Mandatory ¹
	u) 16-GB, PC3L-12800R-11, quad-rank x4*	715284-001	Mandatory ¹
	v) 16-GB, PC3-14900R-13, quad-rank x4*	715274-001	Mandatory ¹
	w) 16-GB, PC3L-10600R-9, dual-rank x4*	664692-001	Mandatory ¹
	x) 16-GB 2Rx4 PC3-10600H-9 HC FIO kit*	684032-001	Mandatory ¹
	y) 32-GB, PC3L-10600L-9, quad-rank x4*	664693-001	Mandatory ¹
	z) 32-GB, PC3-14900L-13, quad-rank x4*	715275-001	Mandatory ¹
	Boards	—	—
15	System board	—	—
	a) Caged heatsink system board	667865-001	Optional ²
	b) Screw-down heatsink system board*	732150-001	Optional ²
	Fans	—	—
16	Fan module	732136-001	Mandatory ¹
	Media devices	—	—
17	DVD-ROM drives	—	—
	a) SATA DVD-ROM drive, 9.5 mm (0.37 in)	652296-001	Mandatory ¹
	b) SATA DVD-RW drive, 9.5 mm (0.37 in)*	652297-001	Mandatory ¹
	Hard drives	—	—
18	Hard drives	—	—
	a) 72-GB, SAS, 6.35 cm (2.5 in)	653949-001	Mandatory ¹
	b) 100-GB, SATA, MLC SSD, 6.35 cm (2.5 in)*	653965-001	Mandatory ¹
	c) 100-GB, SATA, MLC SSD, 8.89 cm (3.5 in)*	653968-001	Mandatory ¹
	d) 146-GB, SAS, 6.35 cm (2.5 in)*	653950-001	Mandatory ¹
	e) 200-GB, SATA, MLC SSD, 6.35 cm (2.5 in)*	653966-001	Mandatory ¹
	f) 200-GB, SATA, MLC SSD, 8.89 cm (3.5 in)*	653969-001	Mandatory ¹
	g) 200-GB, SAS, SLC SSD, 6.35 cm (2.5 in)*	653961-001	Mandatory ¹
	h) 300-GB, SAS, 6.35 cm (2.5 in)*	653955-001	Mandatory ¹
	i) 300-GB, SAS, 6.35 cm (2.5 in)*	653960-001	Mandatory ¹
	j) 400-GB, SATA, MLC SSD, 6.35 cm (2.5 in)*	653967-001	Mandatory ¹
	k) 400-GB, SATA, MLC SSD, 8.89 cm (3.5 in)*	653970-001	Mandatory ¹

Item	Description	Spare part number	Customer self repair (on page 5)
	l) 400-GB, SAS, MLC SSD, 6.35 cm (2.5 in)*	653963-001	Mandatory ¹
	m) 400-GB, SAS, SLC SSD, 6.35 cm (2.5 in)*	653962-001	Mandatory ¹
	n) 450-GB, SAS, 6.35 cm (2.5 in)*	653956-001	Mandatory ¹
	o) 450-GB, SAS, 8.89 cm (3.5 in)*	653951-001	Mandatory ¹
	p) 500-GB, SAS, 6.35 cm (2.5 in)*	653953-001	Mandatory ¹
	q) 500-GB, SATA, 6.35 cm (2.5 in)*	656107-001	Mandatory ¹
	r) 500-GB, SATA, 8.89 cm (3.5 in)*	658103-001	Mandatory ¹
	s) 600-GB, SAS, 6.35 cm (2.5 in)*	653957-001	Mandatory ¹
	t) 600-GB, SAS, 8.89 cm (3.5 in)*	653952-001	Mandatory ¹
	u) 800-GB, SAS, MLC SSD, 6.35 cm (2.5 in)*	653964-001	Mandatory ¹
	v) 900-GB, SAS, 6.35 cm (2.5 in)*	653971-001	Mandatory ¹
	w) 1-TB, SAS, 6.35 cm (2.5 in)*	653954-001	Mandatory ¹
	x) 1-TB, SAS, 8.89 cm (3.5 in)*	653947-001	Mandatory ¹
	y) 1 TB, SATA, 6.35 cm (2.5 in)*	656108-001	Mandatory ¹
	z) 1-TB, SATA, 8.89 cm (3.5 in)*	657739-001	Mandatory ¹
	aa) 2-TB, SAS, 8.89 cm (3.5 in)*	653948-001	Mandatory ¹
	bb) 2-TB, SATA, 8.89 cm (3.5 in)*	658102-001	Mandatory ¹
	cc) 3-TB, SAS, 8.89 cm (3.5 in)*	653959-001	Mandatory ¹
	dd) 3-TB, SATA, 8.89 cm (3.5 in)*	628182-001	Mandatory ¹
	Options	—	—
19	Cache module*	—	—
	a) FBWC module, 512-MB	633540-001	Optional ²
	b) FBWC module, 1-GB	633542-001	Optional ²
	c) FBWC module, 2-GB	633543-001	Optional ²
20	FBWC capacitor pack, 91 cm (36 in)	671353-001	Optional ²
21	PCI riser board options*	—	—
	a) PCIe riser board, x8, LP	667866-001	Optional ²
	b) PCIe riser board, x16, FH, HL	667867-001	Optional ²
	Miscellaneous	—	—
22	HPE Trusted Platform Module*	450168-001	No ³
23	Battery, 3.3-V, lithium*	234556-001	Mandatory ¹
24	AC power cord*	187335-001	Mandatory ¹
	Cables	—	—
25	Hard drive data cable or Mini-SAS cable, 45 cm (18 in)*	667874-001	Mandatory ¹
26	Hard drive data cable or Mini-SAS cable, 64 cm (25 in)*	667875-001	Mandatory ¹

Item	Description	Spare part number	Customer self repair (on page 5)
27	Power to hard drive backplane cable*	667873-001	Mandatory ¹
28	Front video adapter*	671353-001	Optional ²
29	SATA DVD-ROM drive cable*	667879-001	Optional ²
30	Chipset SATA cable*	671353-001	Optional ²
31	Mini-SAS straight cable, 83.82 cm (33 in)*	671353-001	Optional ²

*Not shown

**All processors in this HPE ProLiant server must have the same cache size, speed, number of cores, and rated maximum power consumption.

†Be sure you are using the correct spare part when replacing processors, heatsinks, or system boards.

¹Mandatory—Parts for which customer self repair is mandatory. If you request Hewlett Packard Enterprise to replace these parts, you will be charged for the travel and labor costs of this service.

²Optional—Parts for which customer self repair is optional. These parts are also designed for customer self repair. If, however, you require that Hewlett Packard Enterprise replace them for you, there may or may not be additional charges, depending on the type of warranty service designated for your product.

³No—Some Hewlett Packard Enterprise parts are not designed for customer self repair. In order to satisfy the customer warranty, Hewlett Packard Enterprise requires that an authorized service provider replace the part. These parts are identified as "No" in the Illustrated Parts Catalog.

¹Obligatoire—Pièces pour lesquelles le client doit procéder lui-même aux réparations. Si vous demandez à Hewlett Packard Enterprise de procéder au remplacement de ces pièces, les frais de transport et de main d'œuvre pour ce service vous seront facturés.

²Facultatif—Pièces pour lesquelles une réparation par le client est facultative. Ces pièces sont également conçues pour que le client puisse procéder lui-même aux réparations. Cependant, les frais supplémentaires engendrés par le remplacement de ces pièces par Hewlett Packard Enterprise dépendent du type de service de garantie désigné pour votre produit.

³Non—Certaines pièces Hewlett Packard Enterprise ne sont pas conçues pour être remplacées par le client. Afin de se conformer aux exigences de la garantie la garantie du client, Hewlett Packard Enterprise demande à un fournisseur de services agréé de procéder au remplacement de la pièce. Ces pièces sont signalées par le mot « Non » dans le Catalogue de pièces illustré.

¹Obbligatorio—Parti per le quali il cliente è tenuto a effettuare autonomamente la riparazione. Se si richiede l'intervento di Hewlett Packard Enterprise per la sostituzione di queste parti, al cliente verranno addebitate le spese di viaggio e manodopera dell'operazione.

²Facoltativo—Parti per le quali la riparazione in autonomia da parte del cliente è facoltativa. Queste parti sono progettate per consentire anche la riparazione da parte del cliente. Tuttavia, se il cliente richiede l'intervento di Hewlett Packard Enterprise per la sostituzione, potrebbero essere addebitate spese aggiuntive a seconda del tipo di garanzia in assistenza previsto per il prodotto.

³No—Alcune parti Hewlett Packard Enterprise non sono progettate la riparazione in autonomia da parte del cliente. In base a quanto previsto dalla garanzia per il cliente, Hewlett Packard Enterprise richiede l'intervento di un tecnico autorizzato per la sostituzione della parte. Queste parti sono contrassegnate con "No" nel catalogo parti illustrato.

¹Zwingend—Teile, für die das Customer Self Repair-Verfahren zwingend vorgegeben ist. Wenn Sie den Austausch dieser Teile von Hewlett Packard Enterprise vornehmen lassen, werden Ihnen die Anfahrt- und Arbeitskosten für diesen Service berechnet.

²Optional—Teile, für die das Customer Self Repair-Verfahren optional ist. Diese Teile sind auch für Customer Self Repair ausgelegt. Wenn Sie jedoch den Austausch dieser Teile von Hewlett Packard Enterprise vornehmen lassen möchten, können bei diesem Service je nach den für Ihr Produkt vorgesehenen Garantiebedingungen zusätzliche Kosten anfallen.

³Nein—Einige Hewlett Packard Enterprise Teile sind nicht für Customer Self Repair ausgelegt. Um den Garantieanspruch des Kunden zu erfüllen, muss das Teil von einem Hewlett Packard Enterprise Servicepartner ersetzt werden. Im illustrierten Teilekatalog sind diese Teile mit „No“ bzw. „Nein“ gekennzeichnet.

¹Obligatorio—Componentes cuya reparación por parte del usuario es obligatoria. Si solicita a Hewlett Packard Enterprise que realice la sustitución de estos componentes, tendrá que hacerse cargo de los gastos de desplazamiento y de mano de obra de dicho servicio.

²Opcional—Componentes cuya reparación por parte del usuario es opcional. Estos componentes también están diseñados para que puedan ser reparados por el usuario. Sin embargo, si precisa que Hewlett Packard Enterprise

realice su sustitución, puede o no conllevar costes adicionales, dependiendo del tipo de servicio de garantía correspondiente al producto.

³No—Algunos componentes de Hewlett Packard Enterprise no están diseñados para que puedan ser reparados por el usuario. Para que el usuario haga valer su garantía, Hewlett Packard Enterprise pone como condición que un proveedor de servicios autorizado realice la sustitución de estos componentes. Dichos componentes se identifican con la palabra "No" en el catálogo ilustrado de componentes.

¹Verplicht—Onderdelen die de klant zelf moet vervangen. Als u Hewlett Packard Enterprise vraagt deze onderdelen te vervangen, worden er reis- en arbeidskosten voor deze service in rekening gebracht.

²Optioneel—Onderdelen die de klant zelf kan vervangen. Deze onderdelen zijn ook ontworpen om door de klant zelf te worden vervangen. Als u Hewlett Packard Enterprise verzoekt om deze te vervangen, kan het zijn dat hiervoor extra kosten in rekening worden gebracht, afhankelijk van het soort garantie dat op uw product van toepassing is.

³Geen—Sommige onderdelen van Hewlett Packard Enterprise zijn niet ontworpen om door de klant zelf te worden vervangen. Om te voldoen aan de garantievoorwaarden eist Hewlett Packard Enterprise dat een geautoriseerde serviceverlener het onderdeel vervangt. Deze onderdelen worden aangeduid met 'Geen' in de geïllustreerde onderdelencatalogus.

¹Obrigatório—Peças cujo reparo feito pelo cliente é obrigatório. Se desejar que a Hewlett Packard Enterprise substitua essas peças, serão cobradas as despesas de transporte e mão-de-obra do serviço.

²Opcional—Peças cujo reparo feito pelo cliente é opcional. Essas peças também são projetadas para o reparo feito pelo cliente. No entanto, se desejar que a Hewlett Packard Enterprise as substitua, pode haver ou não a cobrança de taxa adicional, dependendo do tipo de serviço de garantia destinado ao produto.

³Não—Algumas peças da Hewlett Packard Enterprise não são projetadas para o reparo feito pelo cliente. A fim de cumprir a garantia do cliente, a Hewlett Packard Enterprise exige que um técnico autorizado substitua a peça. Essas peças estão identificadas com a marca "No" (Não), no catálogo de peças ilustrado.

¹Mandatory : 必須 — カスタマーセルフリペアが必須の部品。当該部品について、もしもお客様がHewlett Packard Enterpriseに交換作業を依頼される場合には、その修理サービスに関する交通費および人件費がお客様に請求されます。

²Optional : 任意 — カスタマーセルフリペアが任意である部品。この部品もカスタマーセルフリペア用です。当該部品について、もしもお客様がHewlett Packard Enterpriseに交換作業を依頼される場合には、お買い上げの製品に適用される保証サービス内容の範囲内においては、別途費用を負担していただくことなく保証サービスを受けることができます。

³No : 除外 — Hewlett Packard Enterprise製品の一部の部品は、カスタマーセルフリペアの対象外です。製品の保証を継続するためには、Hewlett Packard EnterpriseまたはHewlett Packard Enterprise正規保守代理店による交換作業が必須となります。部品カタログには、当該部品がカスタマーセルフリペア除外品である旨が記載されています。

¹Mandatory — 客户必须自行维修的部件。如果您请求 Hewlett Packard Enterprise 更换这些部件，则必须为该服务支付差旅费和人工费用。

²Optional — 客户可以选择是否自行维修的部件。这些部件也是为客户自行维修设计的。不过，如果您要求 Hewlett Packard Enterprise 为您更换这些部件，则根据为您的产品指定的保修服务类型，Hewlett Packard Enterprise 可能收取或不再收取任何附加费用。

³No — 某些 Hewlett Packard Enterprise 部件的设计并未考虑客户自行维修。为了满足客户保修的需要，Hewlett Packard Enterprise 要求授权服务提供商更换相关部件。这些部件在部件图解目录中标记为“否”。

¹Mandatory — 客戶自行維修所使用的零件是強制性的。如果您要求 Hewlett Packard Enterprise 更換這些零件，Hewlett Packard Enterprise 將會向您收取此服務所需的外出費用與勞動成本。

²Optional — 客戶自行維修所使用的零件是選購的。這些零件也設計用於客戶自行維修之用。不過，如果您要求 Hewlett Packard Enterprise 為您更換，則可能需要也可能不需要負擔額外的費用，端視針對此產品指定的保固服務類型而定。

³No — 某些 Hewlett Packard Enterprise 零件沒有消費者可自行維修的設計。為符合客戶保固，Hewlett Packard Enterprise 需要授權的服務供應商更換零件。這些零件在圖示的零件目錄中，被標示為「否」。

¹Mandatory — 고객 셀프 수리가 의무 사항인 필수 부품. 사용자가 Hewlett Packard Enterprise에 이 부품의 교체를 요청할 경우 해당 서비스에 대한 출장비 및 작업비가 청구됩니다.

²Optional — 고객 셀프 수리가 선택 사항인 부품. 이러한 부품들도 고객 셀프 수리가 가능하도록 설계되었습니다. 하지만 사용자가 Hewlett Packard Enterprise에 이러한 부품의 교체를 요청할 경우 사용자가 구입한 제품에 해당하는 보증 서비스 유형에 따라 추가 비용 없이 교체가 가능할 수 있습니다.

³No — 일부 Hewlett Packard Enterprise 부품은 고객 셀프 수리가 불가능하도록 설계되었습니다. Hewlett Packard Enterprise는 만족스러운 고객 보증을 위해 공인 서비스 제공업체를 통해 부품을 교체하도록 요구하고 있습니다. 이러한 부품들은 Illustrated Parts Catalog에 "No"라고 표시되어 있습니다.

Removal and replacement procedures

Required tools

You need the following items for some procedures:

- T-10/T-15 Torx screwdriver
- HPE Insight Diagnostics software ("HPE Insight Diagnostics" on page 69)

Preparation procedures

To access some components and perform certain service procedures, you must perform one or more of the following procedures:

- Extend the server from the rack (on page 26).
If you are performing service procedures in a Hewlett Packard Enterprise, Compaq branded, Telco, or third-party rack cabinet, you can use the locking feature of the rack rails to support the server and gain access to internal components.
For more information about Telco rack solutions, refer to the RackSolutions.com website (<http://www.racksolutions.com/hpe>).
- Power down the server (on page 25).
If you must remove a server from a rack or a non-hot-plug component from a server, power down the server.
- Remove the server from the rack.
If the rack environment, cabling configuration, or the server location in the rack creates awkward conditions, remove the server from the rack.

Power down the server

Before powering down the server for any upgrade or maintenance procedures, perform a backup of critical server data and programs.



IMPORTANT: When the server is in standby mode, auxiliary power is still being provided to the system.

To power down the server, use one of the following methods:

- Press and release the Power On/Standby button.
This method initiates a controlled shutdown of applications and the OS before the server enters standby mode.
- Press and hold the Power On/Standby button for more than 4 seconds to force the server to enter standby mode.
This method forces the server to enter standby mode without properly exiting applications and the OS. If an application stops responding, you can use this method to force a shutdown.
- Use a virtual power button selection through HPE iLO.
This method initiates a controlled remote shutdown of applications and the OS before the server enters standby mode.

Before proceeding, verify the server is in standby mode by observing that the system power LED is amber.

Extend the server from the rack

NOTE: If the optional cable management arm option is installed, you can extend the server without powering down the server or disconnecting peripheral cables and power cords. These steps are only necessary with the standard cable management solution.

1. Power down the server (on page 25).
2. Disconnect all peripheral cables and power cords.
3. Loosen the front panel thumbscrews.
4. Extend the server on the rack rails until the server rail-release latches engage.



WARNING: To reduce the risk of personal injury or equipment damage, be sure that the rack is adequately stabilized before extending a component from the rack.



WARNING: To reduce the risk of personal injury, be careful when pressing the server rail-release latches and sliding the server into the rack. The sliding rails could pinch your fingers.

5. After performing the installation or maintenance procedure, slide the server into the rack:
 - a. Slide the server fully into the rack.
 - b. Secure the server by tightening the thumbscrews.
6. Connect the peripheral cables and power cords.

Safety considerations

Before performing service procedures, review all the safety information.

Preventing electrostatic discharge

To prevent damaging the system, be aware of the precautions you need to follow when setting up the system or handling parts. A discharge of static electricity from a finger or other conductor may damage system boards or other static-sensitive devices. This type of damage may reduce the life expectancy of the device.

To prevent electrostatic damage:

- Avoid hand contact by transporting and storing products in static-safe containers.
- Keep electrostatic-sensitive parts in their containers until they arrive at static-free workstations.
- Place parts on a grounded surface before removing them from their containers.
- Avoid touching pins, leads, or circuitry.
- Always be properly grounded when touching a static-sensitive component or assembly.

Symbols on equipment

The following symbols may be placed on equipment to indicate the presence of potentially hazardous conditions.



This symbol indicates the presence of hazardous energy circuits or electric shock hazards. Refer all servicing to qualified personnel.

WARNING: To reduce the risk of injury from electric shock hazards, do not open this enclosure. Refer all maintenance, upgrades, and servicing to qualified personnel.



This symbol indicates the presence of electric shock hazards. The area contains no user or field serviceable parts. Do not open for any reason.

WARNING: To reduce the risk of injury from electric shock hazards, do not open this enclosure.



This symbol on an RJ-45 receptacle indicates a network interface connection.

WARNING: To reduce the risk of electric shock, fire, or damage to the equipment, do not plug telephone or telecommunications connectors into this receptacle.



This symbol indicates the presence of a hot surface or hot component. If this surface is contacted, the potential for injury exists.

WARNING: To reduce the risk of injury from a hot component, allow the surface to cool before touching.



14.06-15.97 kg
31.00-35.20 lb

This symbol indicates that the component exceeds the recommended weight for one individual to handle safely.

WARNING: To reduce the risk of personal injury or damage to the equipment, observe local occupational health and safety requirements and guidelines for manual material handling.



These symbols, on power supplies or systems, indicate that the equipment is supplied by multiple sources of power.

WARNING: To reduce the risk of injury from electric shock, remove all power cords to completely disconnect power from the system.

Server warnings and cautions

Before installing a server, be sure that you understand the following warnings and cautions.



WARNING: To reduce the risk of electric shock or damage to the equipment:

- Do not disable the power cord grounding plug. The grounding plug is an important safety feature.
- Plug the power cord into a grounded (earthed) electrical outlet that is easily accessible at all times.
- Unplug the power cord from the power supply to disconnect power to the equipment.
- Do not route the power cord where it can be walked on or pinched by items placed against it. Pay particular attention to the plug, electrical outlet, and the point where the cord extends from the server.



WARNING: To reduce the risk of personal injury from hot surfaces, allow the drives and the internal system components to cool before touching them.



CAUTION: Do not operate the server for long periods with the access panel open or removed. Operating the server in this manner results in improper airflow and improper cooling that can lead to thermal damage.

Access panel

⚠ WARNING: To reduce the risk of personal injury from hot surfaces, allow the drives and the internal system components to cool before touching them.

⚠ CAUTION: Do not operate the server for long periods with the access panel open or removed. Operating the server in this manner results in improper airflow and improper cooling that can lead to thermal damage.

To remove the component:

1. Power down the server (on page 25).
2. Extend the server from the rack (on page 26).
Open or unlock the locking latch, slide the access panel to the rear of the chassis, and remove the access panel.

To replace the component:

1. Place the access panel on top of the server with the hood latch open. Allow the panel to extend past the rear of the server approximately 1.25 cm (0.5 in).
2. Push down on the hood latch. The access panel slides to a closed position.
3. Tighten the security screw on the hood latch.

Drive blank

⚠ CAUTION: To prevent improper cooling and thermal damage, do not operate the server unless all bays are populated with either a component or a blank.

Remove the drive blank.

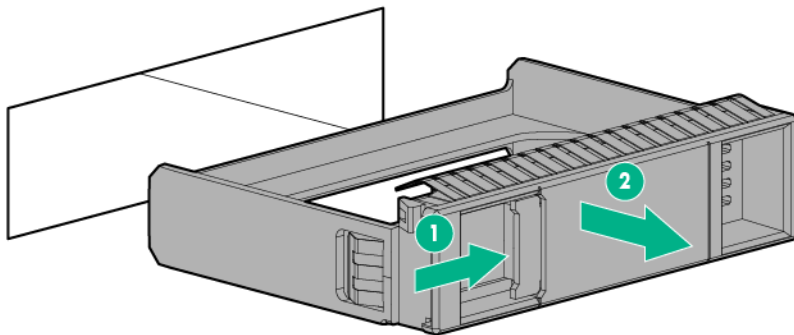

To replace the LFF drive blank, slide the component into the bay until it clicks.

To replace the SFF drive blank, while pressing the release latch, slide the component into the bay until it is fully seated.

Hot-plug drive

⚠ CAUTION: For proper cooling, do not operate the server without the access panel, baffles, expansion slot covers, or blanks installed. If the server supports hot-plug components, minimize the amount of time the access panel is open.

1. Determine the status of the drive from the hot-plug drive LED definitions (on page 83).
2. Back up all server data on the drive.

3. Remove the drive.

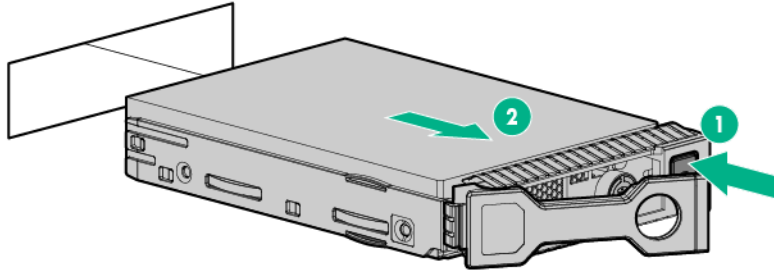

To replace the component, reverse the removal procedure.

Power supply blank

Remove the blank.

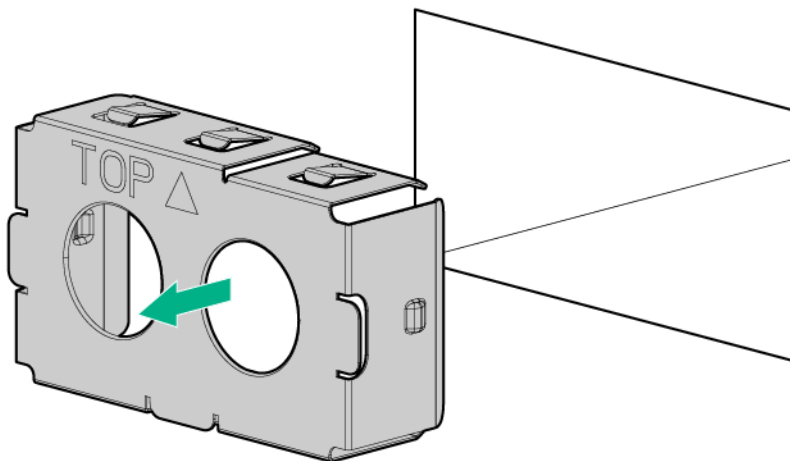

To replace the component, reverse the removal procedure.

AC power supply

CAUTION: To prevent improper cooling and thermal damage, do not operate the server unless all bays are populated with either a component or a blank.

To remove the component:

1. Power down the server (on page 25).
2. Remove all power:
 - a. Disconnect each power cord from the power source.
 - b. Disconnect each power cord from the server.
3. Access the product rear panel.
4. Remove the power supply.

WARNING: To reduce the risk of personal injury from hot surfaces, allow the power supply or power supply blank to cool before touching it.

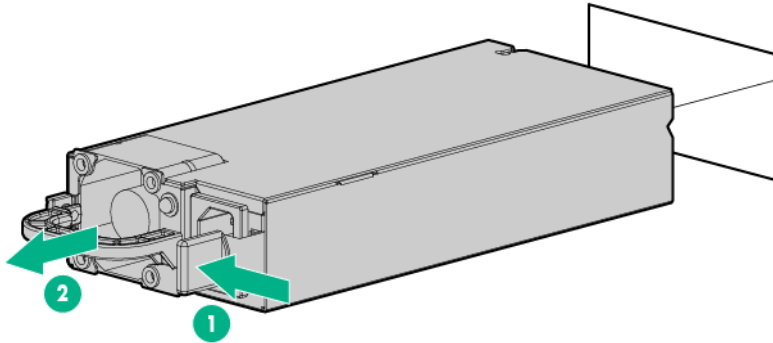

To replace the component, reverse the removal procedure.

48V DC power supply option

One of the following optional input cables with pre-fastened ring tongues may be purchased from Hewlett Packard Enterprise or an authorized reseller:

- A5S97A—1.3-m (7.55-ft) 48V DC Power Cable Kit
- A5S98A—2.5-m (3.94-ft) 48V DC Power Cable Kit

If you are not using an optional input cable, use a Hewlett Packard Enterprise-approved 10 or 12 AWG green and yellow ground cable, no shorter than 150 cm (59.06 in), and 10 or 12 AWG power cables.

CAUTION: Use only the ring terminals provided with the power supply for customer-built power connections. Be sure no wire protrudes from the bottom of the ring terminal barrels.

To remove the component:

1. Make sure the 48V DC power source is off or the PDU breaker is in the off position, and then disconnect the power cord from the 48V DC power source or PDU.
2. Remove the power cord from the cable management arm, if installed.

3. Remove the safety cover.

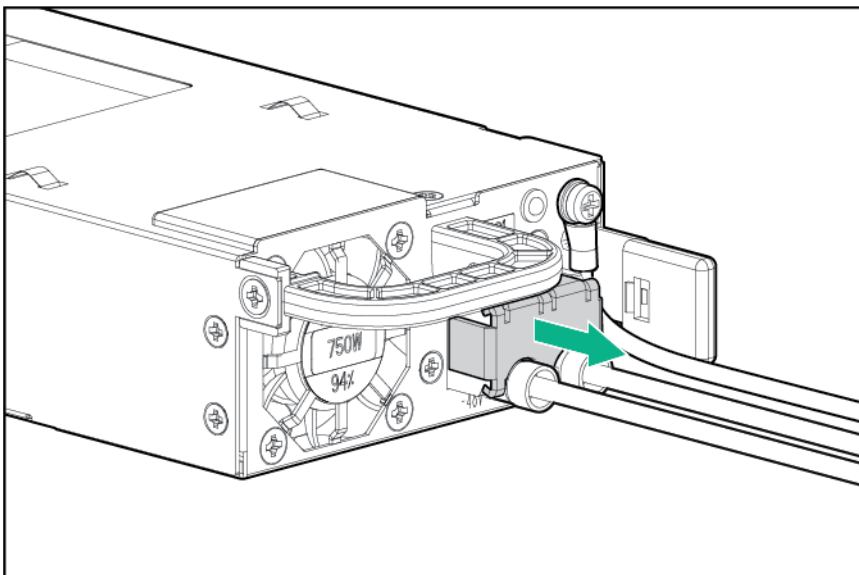

4. Remove the power ring tongues from the terminal block.

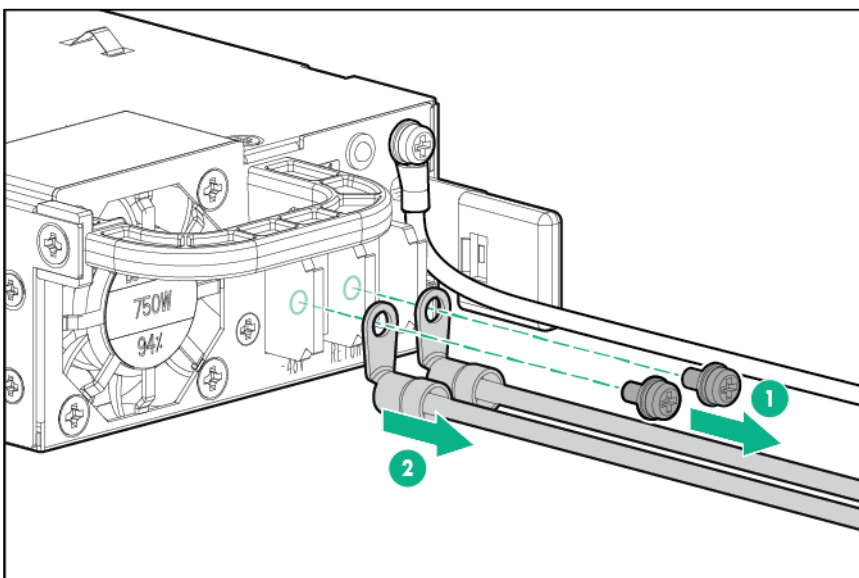

5. Remove the ground (earthed) wire from the ground screw and washer.

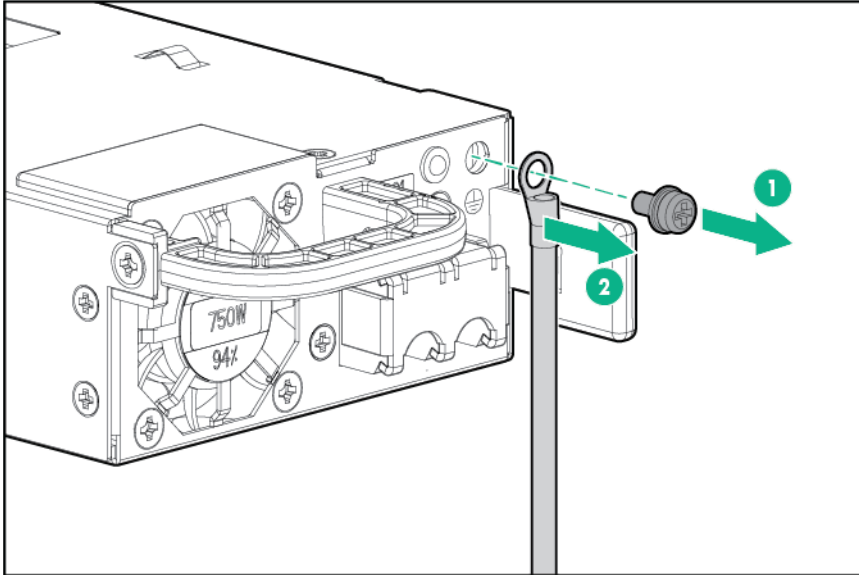

6. Attach the screws to the terminal block.



IMPORTANT: The minimum nominal thread diameter of a pillar or stud type terminal must be 3.5 mm (0.138 in); the diameter of a screw type terminal must be 4.0 mm (0.157 in).

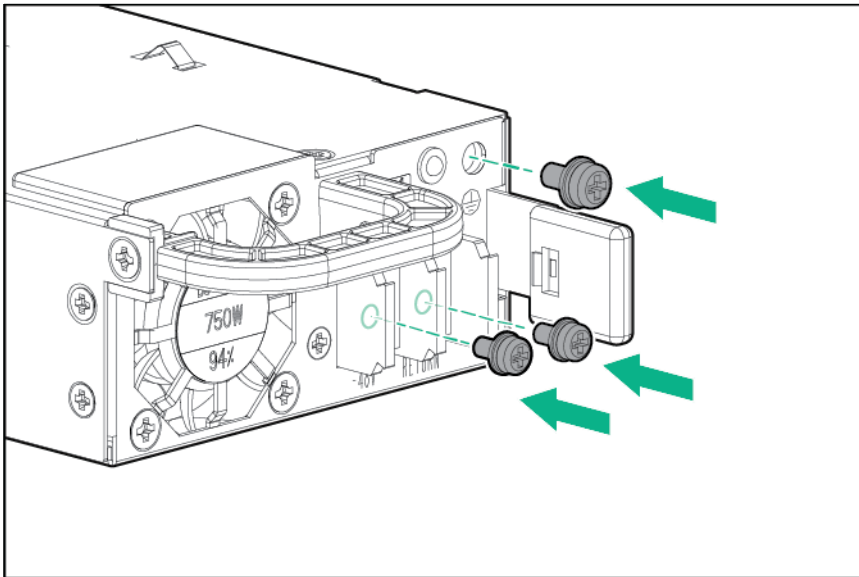

7. Remove the power supply from the power supply bay.

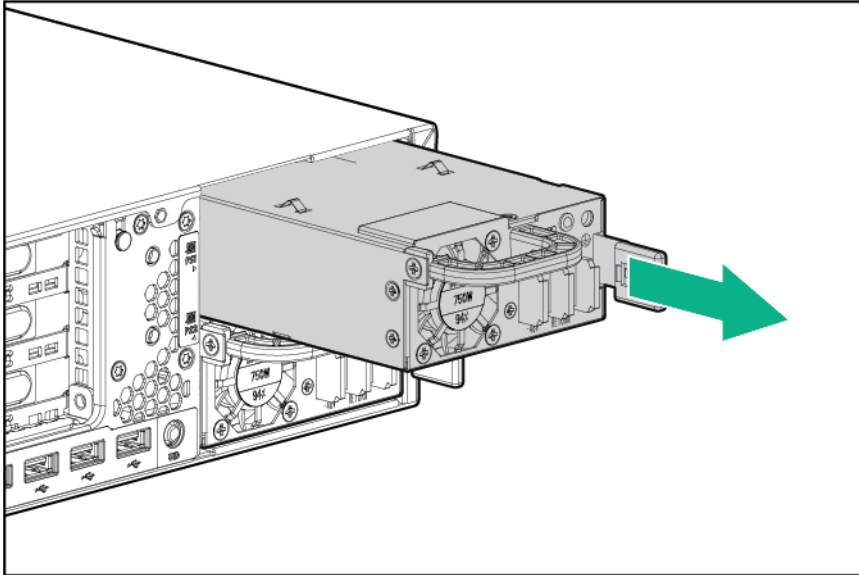

8. If you are not immediately replacing the power supply, install the safety cover.

To replace the component:

1. If you are not using an optional Hewlett Packard Enterprise input cable or the ring tongues you crimped previously, with the ground cable disconnected from the 48V power source, crimp the ring tongues to the power and ground cables coming from the 48V source.



IMPORTANT: The power supply uses two power ring tongues and one ground ring tongue. They are not interchangeable.

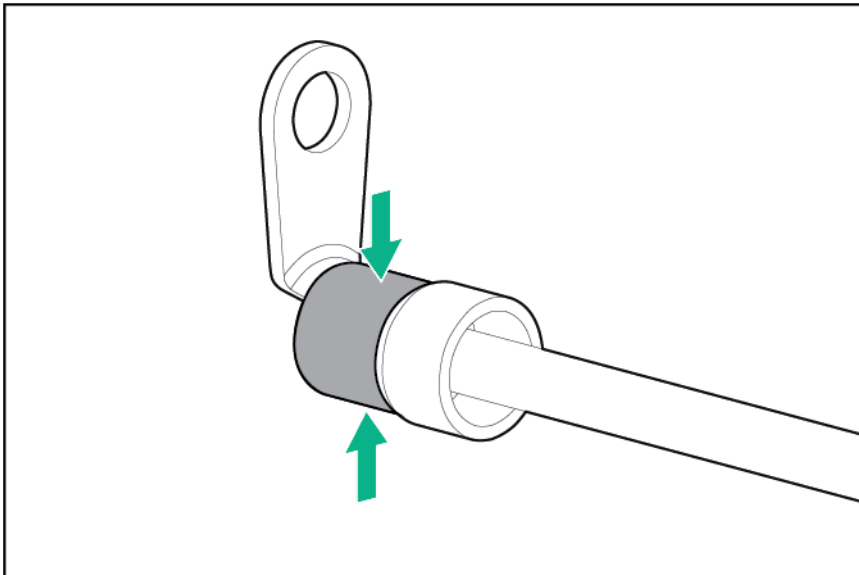

2. Remove the safety cover from the terminal block on the front of the power supply.

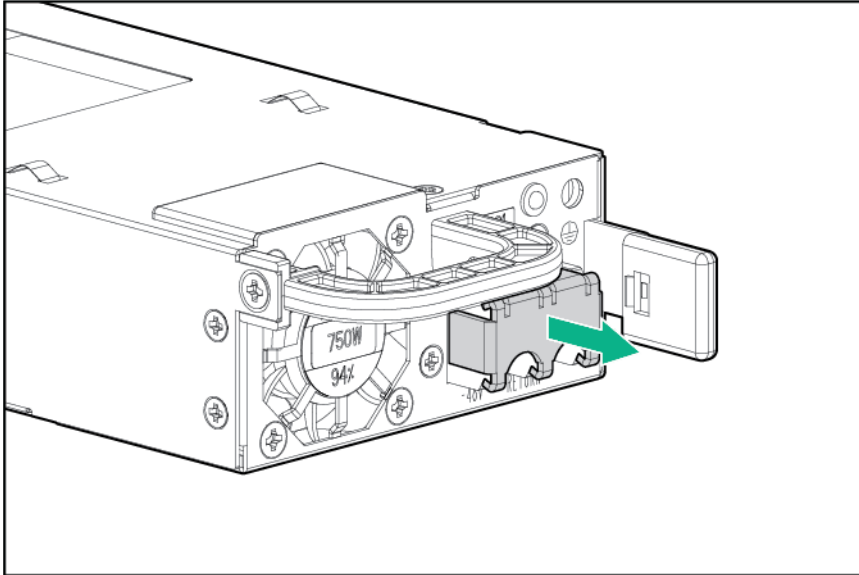

3. Remove the screws from the terminal block.



IMPORTANT: The minimum nominal thread diameter of a pillar or stud type terminal must be 3.5 mm (0.138 in); the diameter of a screw type terminal must be 4.0 mm (0.157 in).

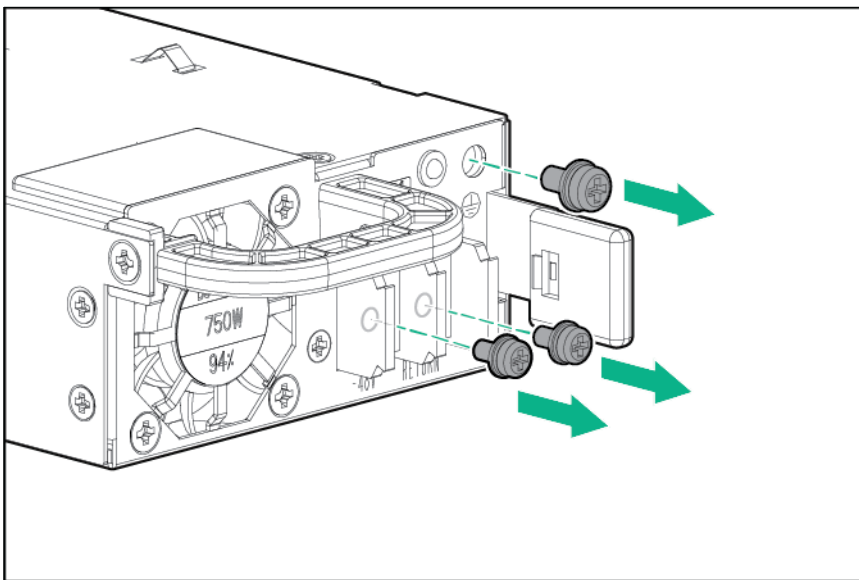

4. Attach the ground (earthed) wire to the ground screw and washer and tighten to 1.47 N m (13 lb-in) of torque. The ground wire must be connected before the positive or negative lead wires.

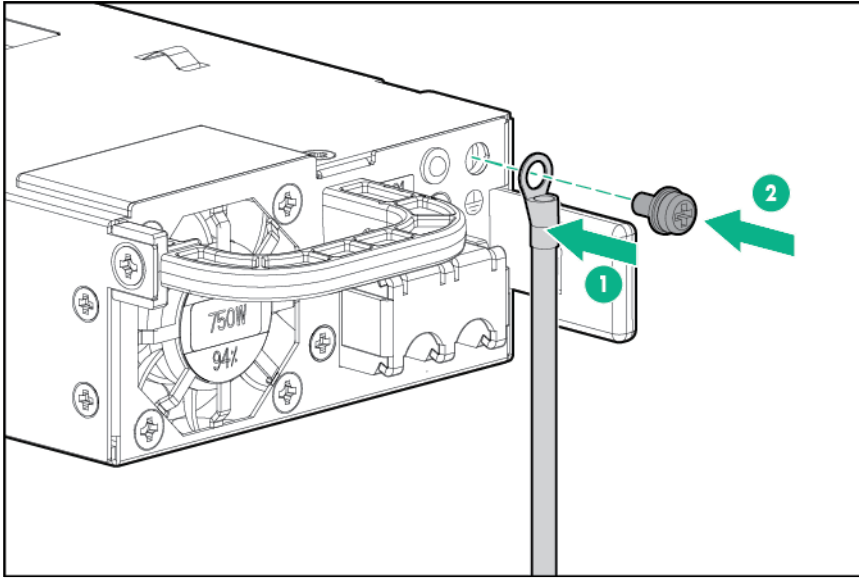

5. Attach the power ring tongues to the terminal block, following the polarity label below the terminal block, and then tighten the screws to 1.47 N m (13 lb-in) of torque.

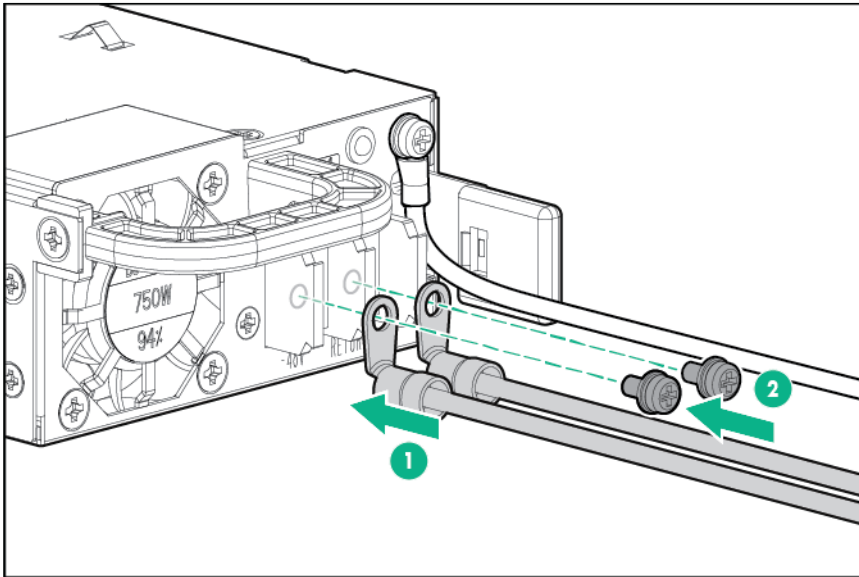

6. Replace the safety cover.

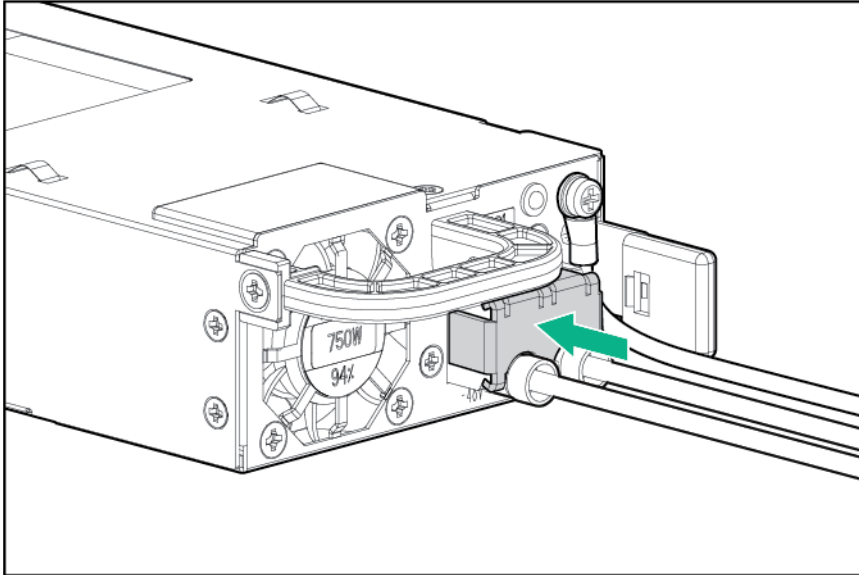

7. Insert the power supply into the power supply bay until it clicks into place.

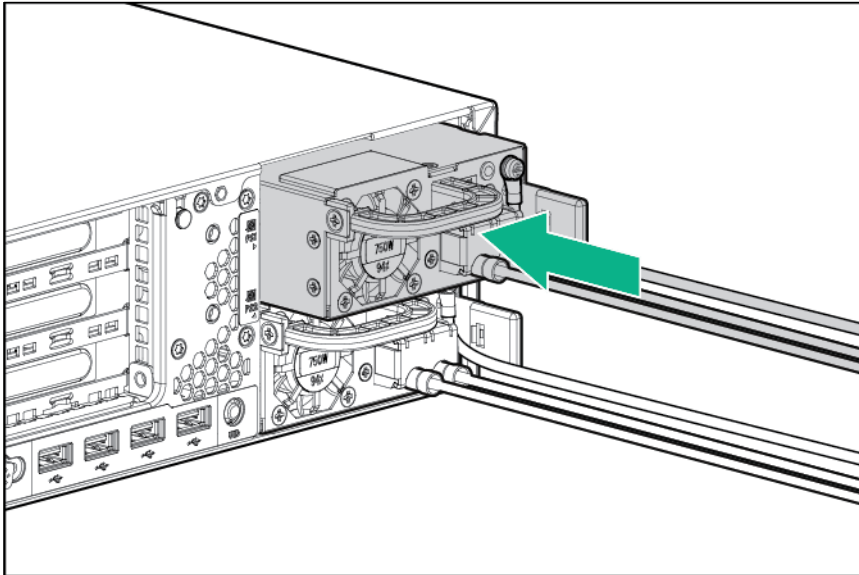

8. Route the power cord. Use best practices when routing power cords and other cables. A cable management arm is available to help with routing. To obtain a cable management arm, contact a Hewlett Packard Enterprise authorized reseller.
9. Make sure the 48V DC power source is off or the PDU breaker is in the off position, and then connect the power cord to the 48V DC power source or PDU.
10. Turn on the 48V power source or switch the PDU breaker to the on position to supply 48V to the power supply.

Be sure that the green power supply LED is on.

Drive cage assembly

The hard drive cage assembly includes the Systems Insight Display ("[Systems Insight Display LEDs](#)" on page [80](#)), front panel LEDs and buttons (on page [74](#)), drive backplane, and cables.

To remove the component:

1. Power down the server (on page 25).
2. Remove all power:
 - a. Disconnect each power cord from the power source.
 - b. Disconnect each power cord from the server.
3. Extend the server from the rack (on page 26).
4. Remove all drives ("Hot-plug drive" on page 28).
5. Disconnect all cables connected to the hard drive backplane from the system board.
6. Remove the hard drive cage assembly.

The server may look different than the one shown in the following illustration, depending on the server model.

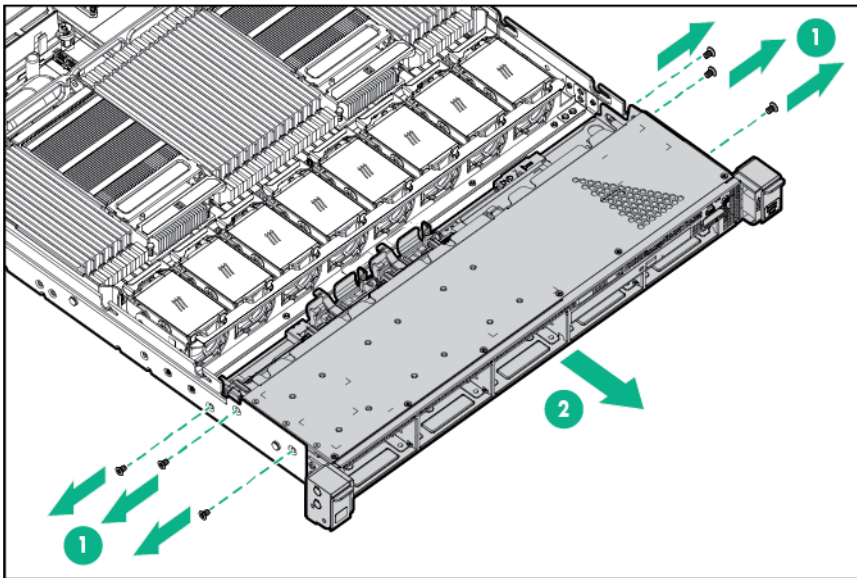

To replace the component, reverse the removal procedure.

DVD-ROM or DVD-RW drive

All configurations of this server, except the 10 SFF drive configuration, support the installation of a DVD-ROM drive or a DVD-RW drive.

To remove the component:

1. Power down the server (on page 25).
2. Remove all power:
 - a. Disconnect each power cord from the power source.
 - b. Disconnect each power cord from the server.
3. Extend the server from the rack (on page 26).
4. Remove the access panel ("Access panel" on page 27).
5. If installed, remove the FBWC capacitor pack ("FBWC capacitor pack" on page 41).
6. For SFF drives, do the following:
 - a. Disconnect the SATA DVD cable from the system board to fully remove the DVD drive from the bay ("DVD-ROM and DVD-RW drive cabling" on page 65).

- b. Remove the DVD drive from the server.

The server may look different than the one shown in the following illustration, depending on the server model.

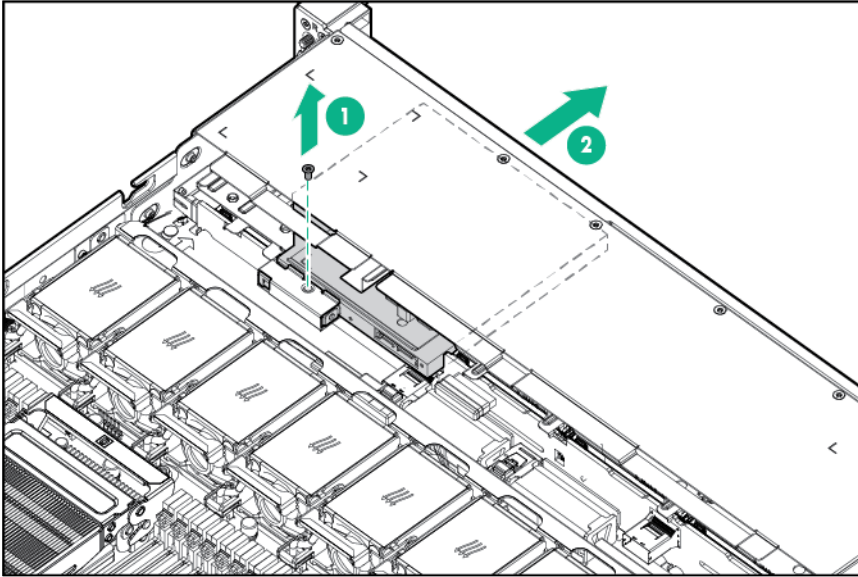

- c. Disconnect the SATA DVD cable from the rear of the DVD drive.
7. For LFF drives, do the following:
- a. Remove the DVD drive from the server.
You may need to disconnect the SATA DVD cable from the system board to fully remove the DVD drive from the drive bay.
 - b. Disconnect the SATA DVD cable from the rear of the DVD drive ("[DVD-ROM and DVD-RW drive cabling](#)" on page 65).

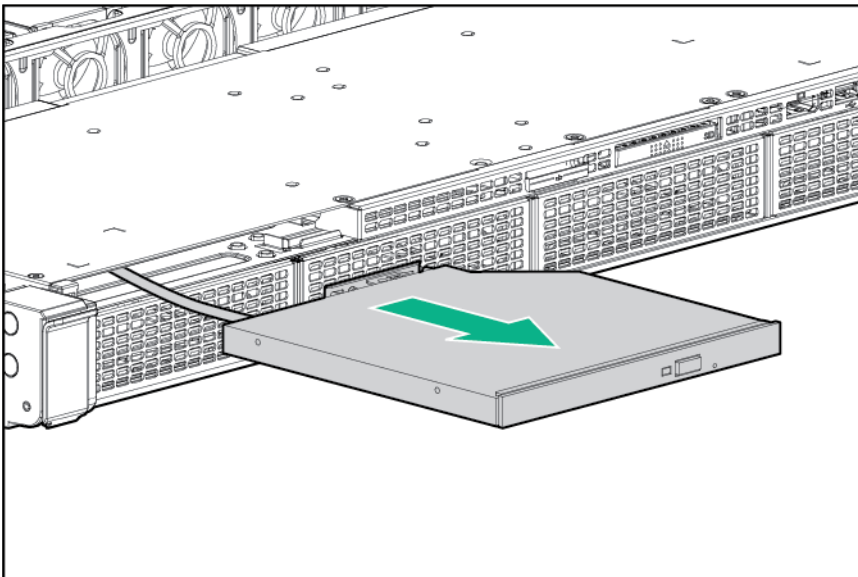

To replace the component, reverse the removal procedure.

Fan module

The server has eight fans. Install fans 1 and 2 only when processor 2 is installed. When only one processor is installed, install the fan blanks in bays 1 and 2 ("Fan modules" on page 84).

To remove the component:

1. Extend the server from the rack (on page 26).
2. Remove the access panel ("Access panel" on page 27).

⚠ CAUTION: To avoid server shutdown, a fan must be replaced within 60 seconds of being removed.

3. Remove the fan module.

The illustration shows fans 1 and 2 removed for a single-processor configuration.

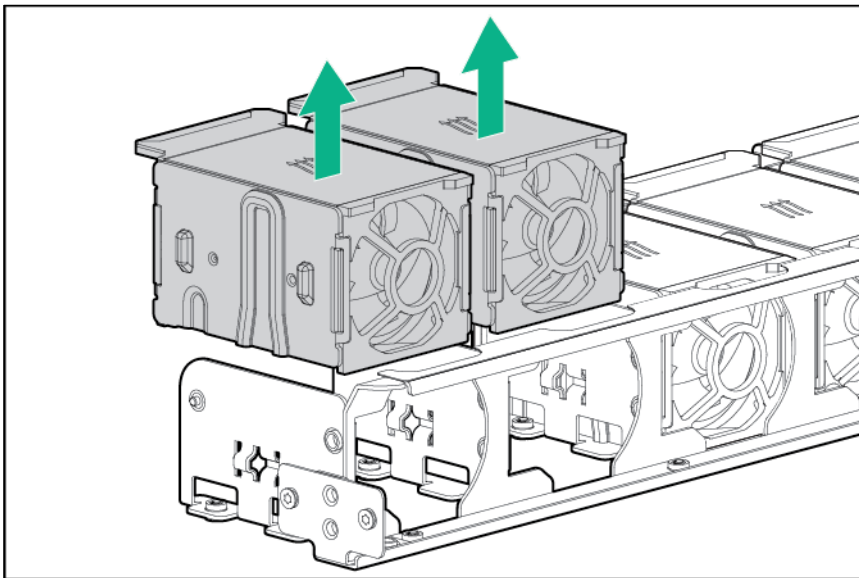

To replace the component:

1. Install the fan module.

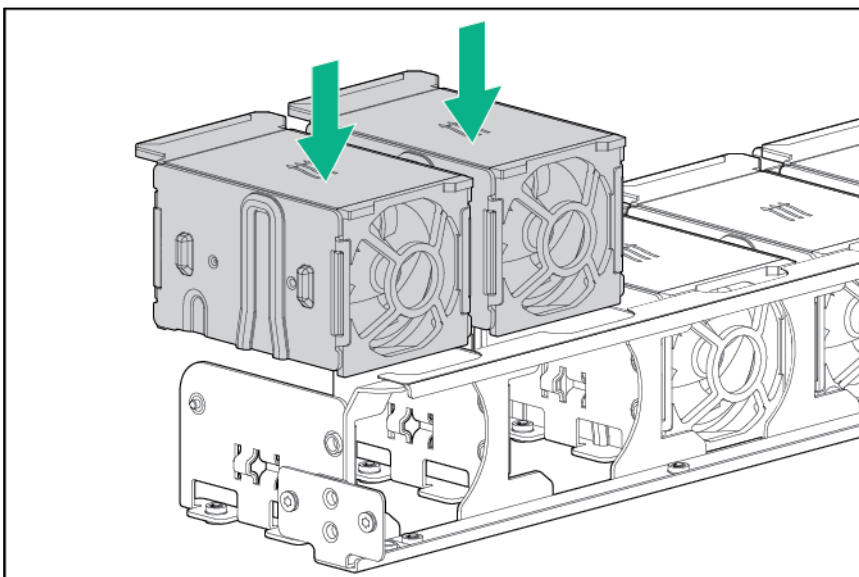

2. Install the access panel ("[Access panel](#)" on page 27).
3. Slide the server into the rack.
4. Power up the server.

Fan blank

Install fans 1 and 2 only when processor 2 is installed. When only one processor is installed, install the fan blanks in bays 1 and 2 ("[Fan modules](#)" on page 84).

To remove the component:

1. Power down the server (on page 25).
2. Remove all power:
 - a. Disconnect each power cord from the power source.
 - b. Disconnect each power cord from the server.
3. Extend the server from the rack (on page 26).
4. Remove the access panel ("[Access panel](#)" on page 27).
5. Remove the fan blanks.

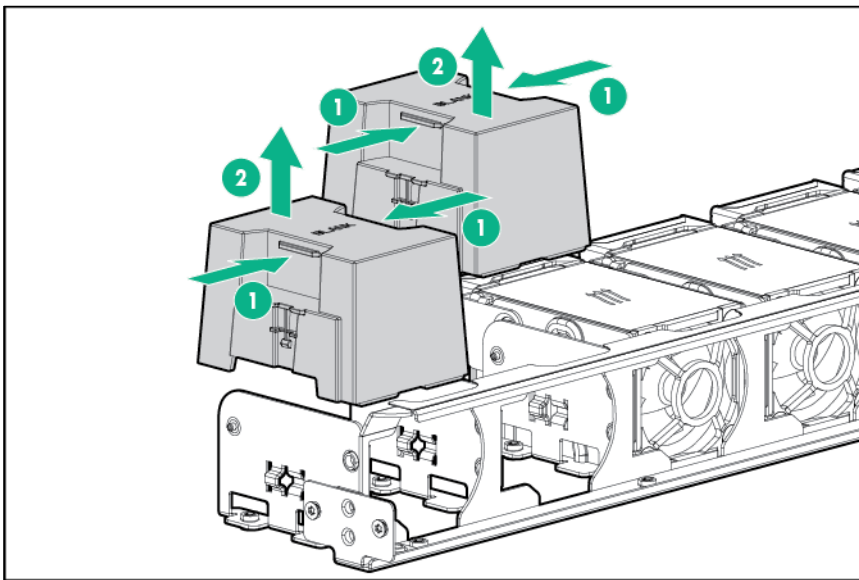

To replace the component, reverse the removal procedure.

Flash-backed write cache procedures

Two types of procedures are provided for the FBWC option:

- Removal and replacement of failed components:
 - Removing the cache module ("[Cache module](#)" on page 41)
 - Removing the capacitor pack ("[FBWC capacitor pack](#)" on page 41)
- Recovery of cached data from a failed server ("[Recovering data from the flash-backed write cache](#)" on page 42)



CAUTION: Do not detach the cable that connects the battery pack or capacitor pack to the cache module. Detaching the cable causes all data in the cache module to be lost.

Cache module

To remove the component:

1. Power down the server (on page 25).
2. Remove all power:
 - a. Disconnect each power cord from the power source.
 - b. Disconnect each power cord from the server.
3. Extend the server from the rack (on page 26).
4. Remove the access panel ("Access panel" on page 27).
5. If installed, remove the FBWC capacitor pack ("FBWC capacitor pack" on page 41).
6. Remove the PCI riser cage ("PCI riser cage" on page 46).
7. Remove the cache module.

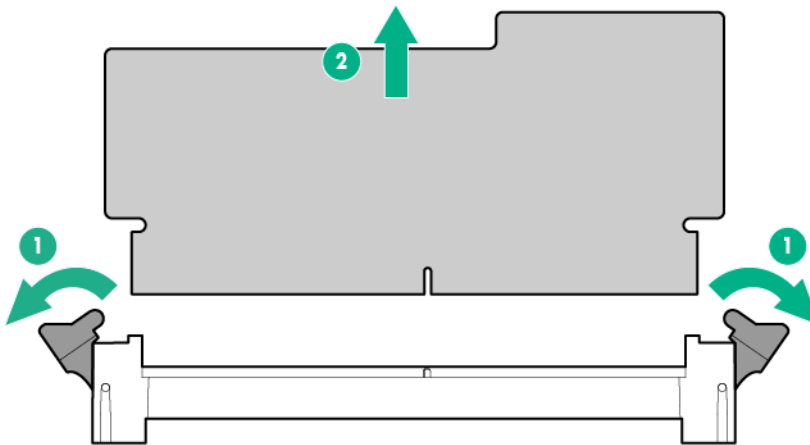

To replace the component, reverse the removal procedure.



IMPORTANT: A cache module is required for a 10 SFF drive cage. Drives installed in a 10 SFF configuration do not function without a cache module.

FBWC capacitor pack



CAUTION: To prevent a server malfunction or damage to the equipment, do not add or remove the battery pack while an array capacity expansion, RAID level migration, or stripe size migration is in progress.

To remove the component:

1. Power down the server (on page 25).
2. Remove all power:
 - a. Disconnect each power cord from the power source.
 - b. Disconnect each power cord from the server.
3. Extend the server from the rack (on page 26).
4. Remove the access panel ("Access panel" on page 27).

5. Disconnect the cable from the cache module or PCIe controller.
6. Remove the FBWC capacitor pack.

The server may look different than the one shown in the following illustration, depending on the server model.

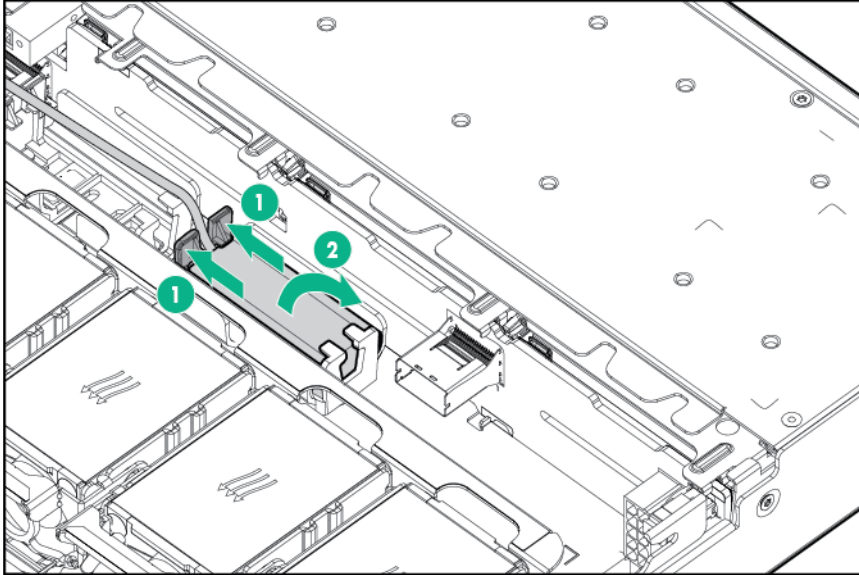

To replace the component, reverse the removal procedure.

Recovering data from the flash-backed write cache

If the server fails, use the following procedure to recover data temporarily stored in the FBWC.

CAUTION: Before starting this procedure, read the information about protecting against electrostatic discharge ("[Preventing electrostatic discharge](#)" on page 26).

1. Perform one of the following:
 - o Set up a recovery server using an identical server model. Do not install any internal drives or FBWC in this server. (Hewlett Packard Enterprise recommends this option.)
 - o Find a server that has enough empty drive bays to accommodate all the drives from the failed server and that meets all the other requirements for drive and array migration.
2. Power down the failed server ("[Power down the server](#)" on page 25).
3. Transfer the drives from the failed server to the recovery server.
4. Perform one of the following:
 - o If the array controller has failed, remove the cache module and capacitor pack from the failed array controller, and install the cache module and capacitor pack on an identical array controller model in the recovery server.
 - o If the server has failed, remove the controller, cache module, and capacitor pack from the failed server, and install the controller, cache module, and capacitor pack in the recovery server.
5. Power up the recovery server. If there was data in the cache at the time of the controller or server failure, a 1792 POST message appears, stating that valid data was flushed from the cache. This data is now stored on the drives in the recovery server. You can now transfer the drives (and controller, if one is used) to another server.

If the drives are migrated to different drive positions or there are volumes present in the recovery server, a 1724 POST message appears, stating that logical drive configuration has been updated automatically.

Front video adapter

Depending on the model purchased, the server may look different than shown.

The 10 SFF drive configuration does not support the front video adapter.

Remove the component as indicated.

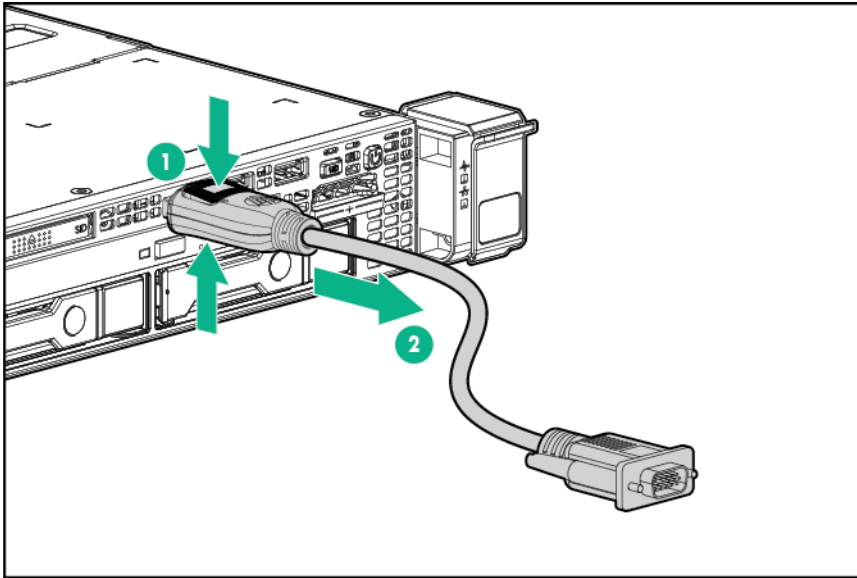

CAUTION: Be sure to connect the video adapter to the video connector, and not to the USB connector.

To replace the component, reverse the removal procedure.

The 10 SFF drive configuration does not support the front video adapter.

FlexibleLOM

To remove the component:



WARNING: To reduce the risk of personal injury, electric shock, or damage to the equipment, remove the power cord to remove power from the server. The front panel Power On/Standby button does not completely shut off system power. Portions of the power supply and some internal circuitry remain active until AC power is removed.

1. Power down the server (on page 25).
2. Remove all power:
 - a. Disconnect each power cord from the power source.
 - b. Disconnect each power cord from the server.
3. Remove any attached network cables.
4. Extend the server from the rack (on page 26).
5. Remove the access panel ("Access panel" on page 27).
6. Loosen the thumbscrew.

7. Remove the existing FlexibleLOM.

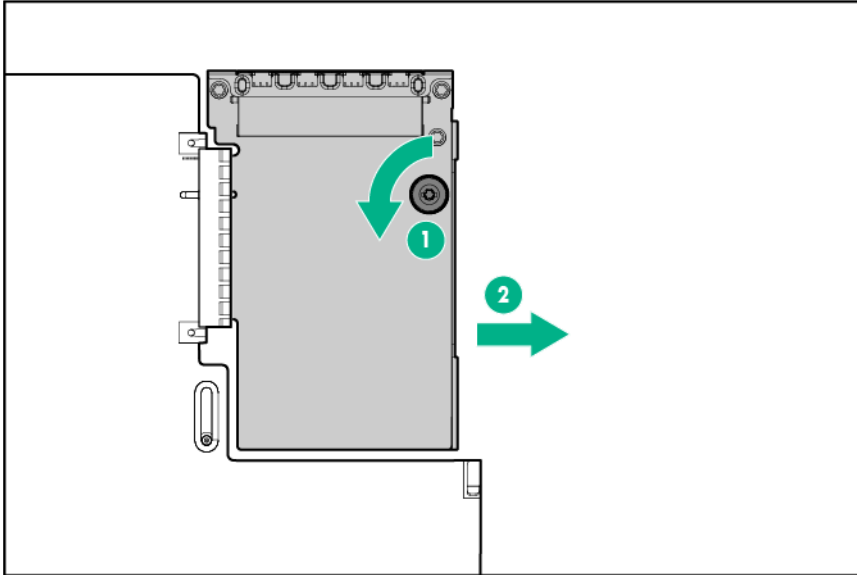

To replace the component:

1. Firmly seat the FlexibleLOM in the slot, and then tighten the thumbscrew.

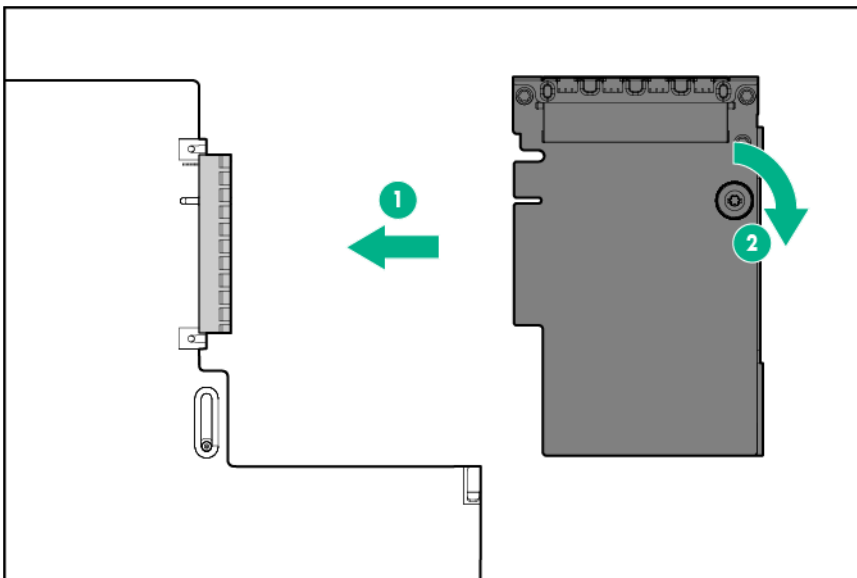

2. Install the access panel ("[Access panel](#)" on page 27).
3. Slide the server into the rack.
4. Connect the LAN segment cables.
5. Connect each power cord to the server.
6. Connect each power cord to the power source.
7. Power up the server.

Rack bezel

Remove the component as indicated.

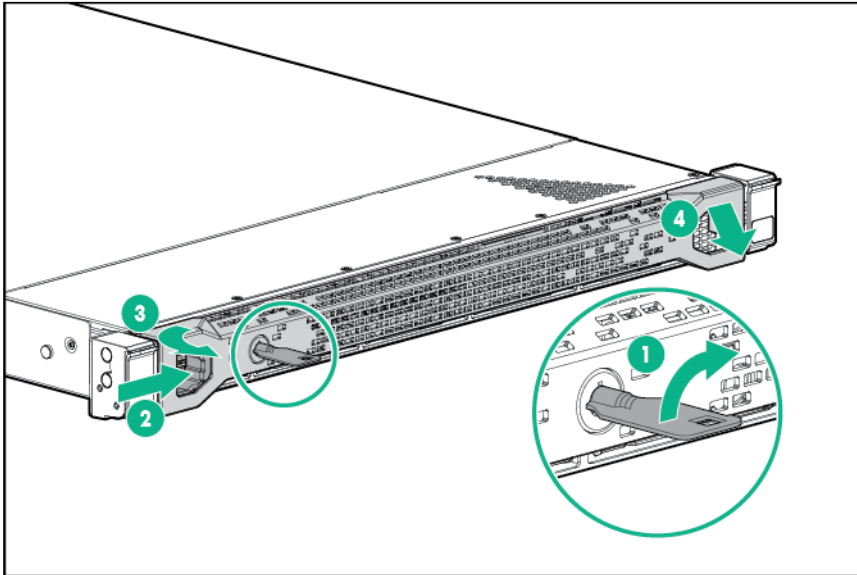

To replace the component, reverse the removal procedure.

Air baffle

To remove the component:

1. Power down the server (on page 25).
2. Remove all power:
 - a. Disconnect each power cord from the power source.
 - b. Disconnect each power cord from the server.
3. Extend the server from the rack (on page 26).
4. Remove the access panel ("[Access panel](#)" on page 27).
5. Remove the SATA cable if it is clipped to the air baffle.
6. Remove the air baffle.

The server may look different than the one shown in the following illustration, depending on the server model.

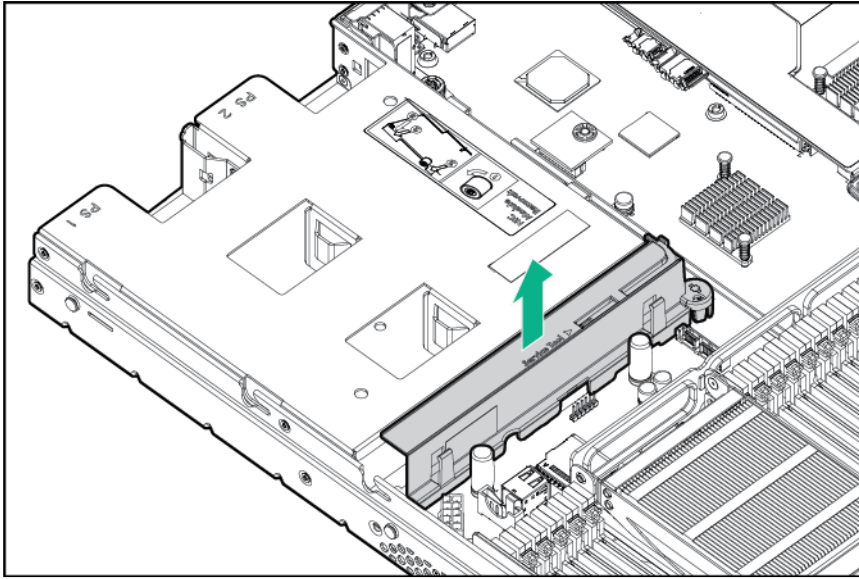

To replace the component, reverse the removal procedure.

PCI riser cage

To remove the component:



CAUTION: To prevent damage to the server or expansion boards, power down the server and remove all AC power cords before removing or installing the PCI riser cage.

1. Power down the server (on page 25).
2. Remove all power:
 - a. Disconnect each power cord from the power source.
 - b. Disconnect each power cord from the server.
3. Extend the server from the rack (on page 26).
4. Remove the access panel ("Access panel" on page 27).
5. Remove the PCI riser cage:
 - a. Disconnect external cables connected to any existing expansion boards.
 - b. Disengage the two PCI riser cage thumbscrews. Lift the tab, rotate 180 degrees, and the thumbscrew pops up.
 - c. Lift the assembly to unseat the PCI riser boards, and then remove the cage.

The server may look different than the one shown in the following illustration, depending on the server model.

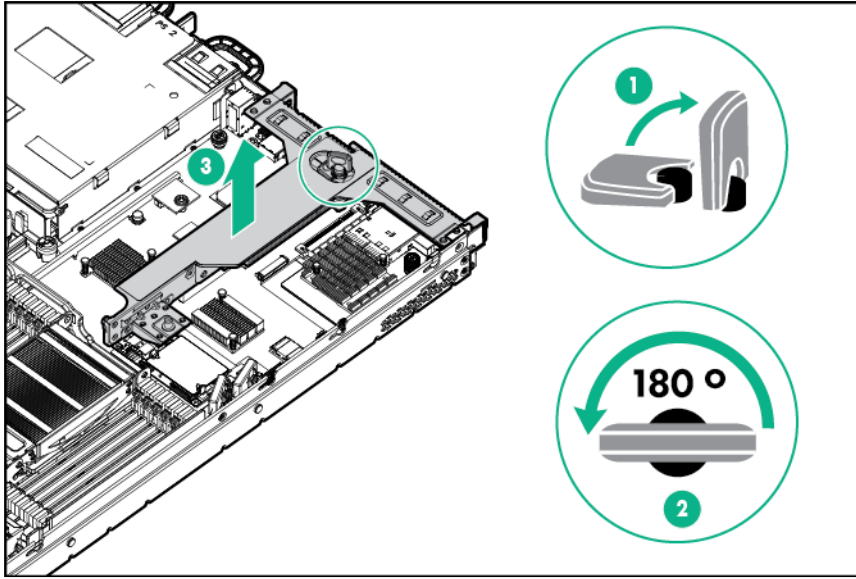

To replace the component, reverse the removal procedure.

Expansion boards

To remove the component:

1. Power down the server (on page 25).
2. Remove all power:
 - a. Disconnect each power cord from the power source.
 - b. Disconnect each power cord from the server.
3. Extend the server from the rack (on page 26).
4. Remove the access panel ("Access panel" on page 27).
5. Remove the PCIe riser cage ("PCI riser cage" on page 46).
6. Remove the expansion board.

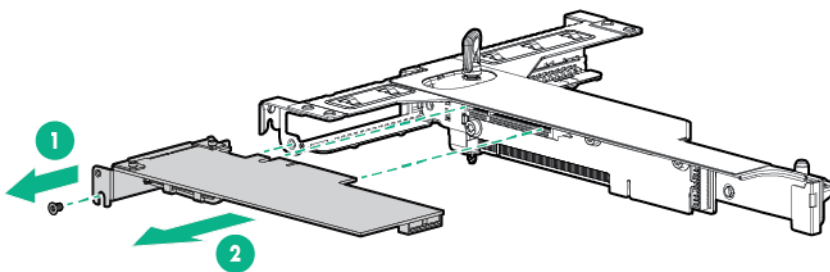

To replace the component, reverse the removal procedure.

If you are not replacing the expansion board, install the screw back into the PCIe riser cage before installing the PCIe riser cage back into the server.

PCIe riser board

To remove the component:

1. Power down the server (on page 25).
2. Remove all power:
 - a. Disconnect each power cord from the power source.
 - b. Disconnect each power cord from the server.
3. Extend the server from the rack (on page 26).
4. Remove the access panel ("Access panel" on page 27).
5. Remove the PCI riser cage ("PCI riser cage" on page 46).
6. Remove any installed expansion boards ("Flash-backed write cache procedures" on page 40, "Expansion boards" on page 47).
7. Remove the PCIe riser board.

The x16 PCIe riser board (shown) has 2 screws to remove from the assembly; the x8 PCIe riser board (on the other side of the PCI riser cage) has 3 screws to remove from the assembly.

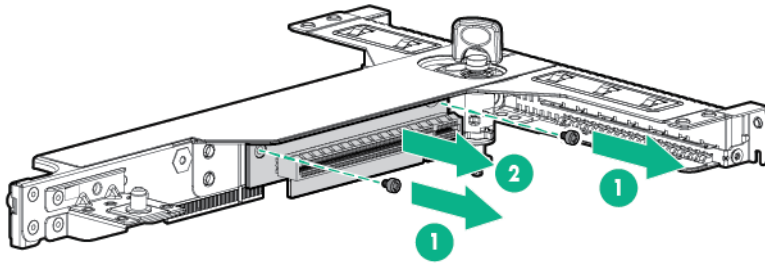

To replace the component, reverse the removal procedure.

DIMMs

To remove the component:

1. Power down the server (on page 25).
2. Remove all power:
 - a. Disconnect each power cord from the power source.
 - b. Disconnect each power cord from the server.
3. Extend the server from the rack (on page 26).
4. Remove the access panel ("Access panel" on page 27).
5. If installed, remove the FBWC capacitor pack ("FBWC capacitor pack" on page 41).

6. Remove the DIMM.

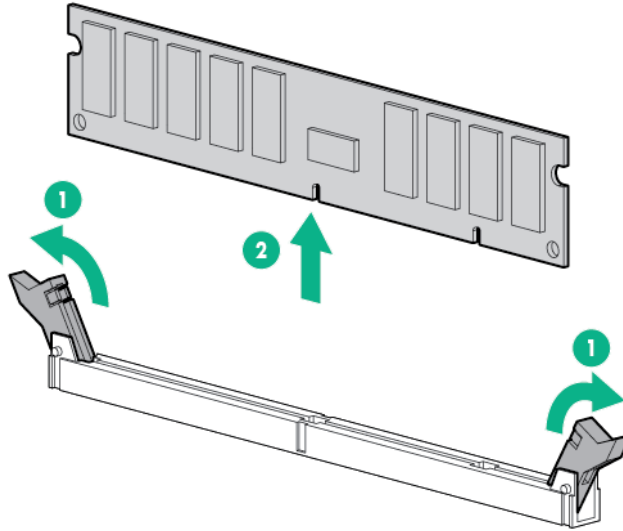

To replace the component, reverse the removal procedure.

Heatsink

-
- ⚠ **WARNING:** To reduce the risk of personal injury from hot surfaces, allow the drives and the internal system components to cool before touching them.
-
- ⚠ **CAUTION:** The heatsink thermal interface media is not reusable and must be replaced if the heatsink is removed from the processor after it has been installed.
-
- ⚠ **CAUTION:** To avoid thermal shutdown, all fans must be installed in a dual processor configuration.
-

To remove the component:

1. Power down the server (on page 25).
2. Remove all power:
 - a. Disconnect each power cord from the power source.
 - b. Disconnect each power cord from the server.
3. Remove the server from the rack.
4. Remove the access panel ("Access panel" on page 27).
5. Remove the heatsink.

- o Caged heatsink

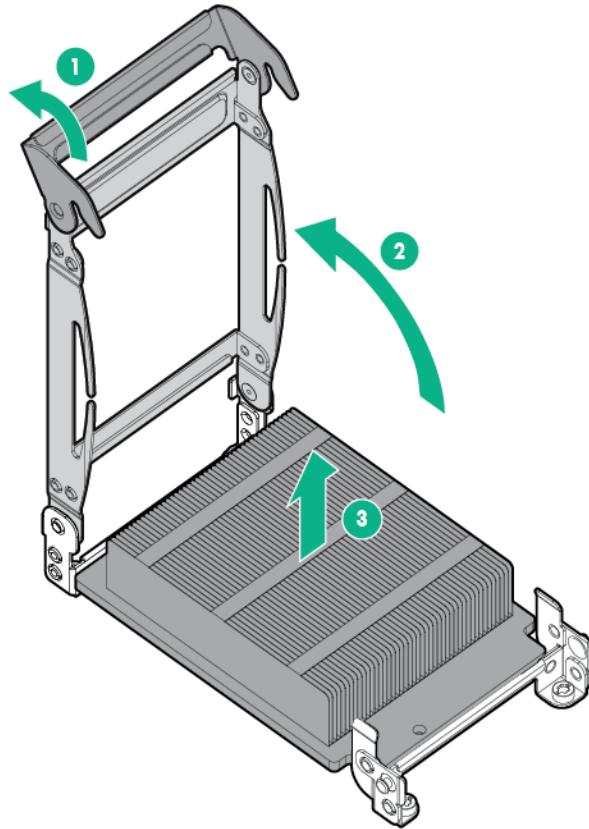

- o Screw-down heatsink

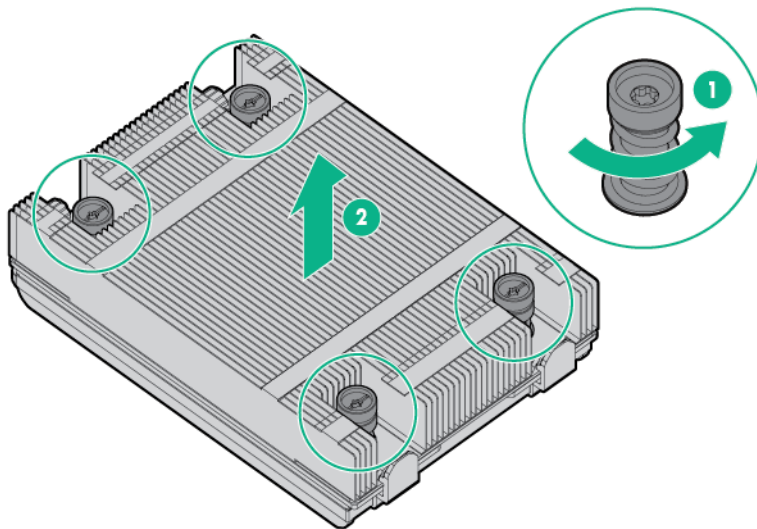

To replace the component:

1. Remove the thermal interface protective cover from the heatsink.

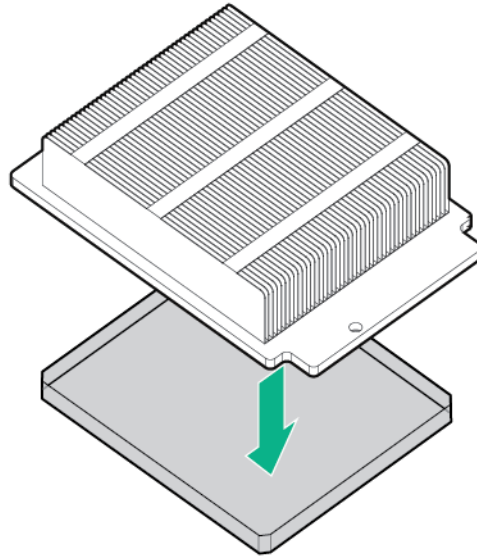

2. Install the heatsink, ensuring the alignment bracket aligns on the front of the heatsink.
 - o Caged heatsink

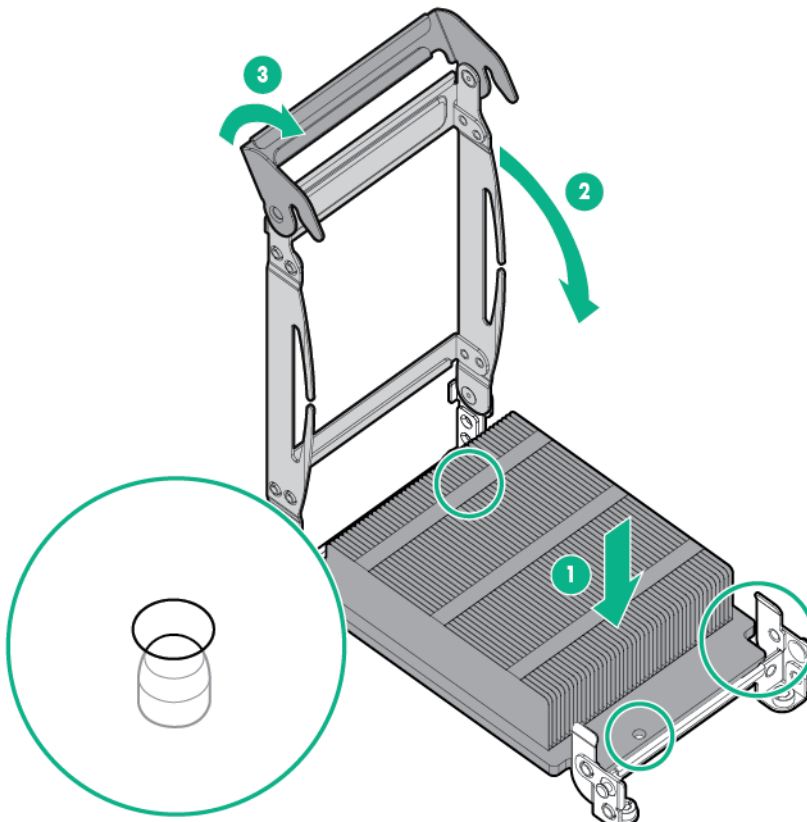

- o Screw-down heatsink

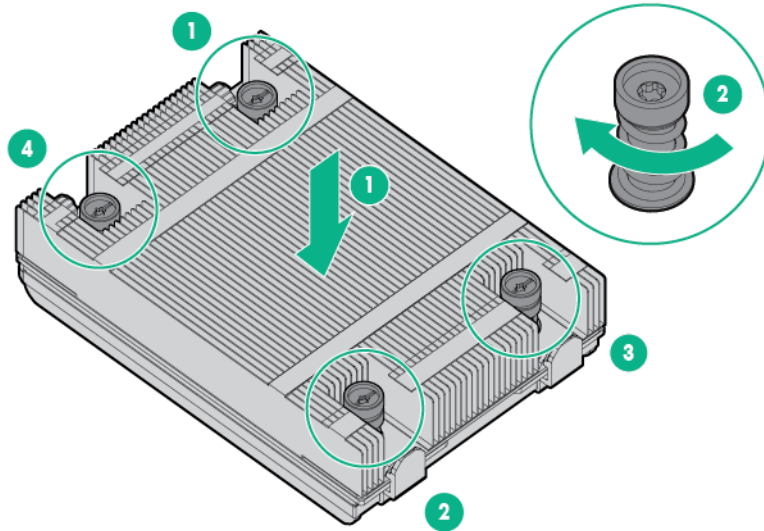

3. Install the access panel ("Access panel" on page 27).
4. Slide the server into the rack.
5. Connect each power cord to the server.
6. Connect each power cord to the power source.
7. Power up the server.

Processor

- ⚠ WARNING:** To reduce the risk of personal injury from hot surfaces, allow the drives and the internal system components to cool before touching them.

- ⚠ CAUTION:** To prevent possible server malfunction and damage to the equipment, multiprocessor configurations must contain processors with the same part number.

- ⚠ CAUTION:** The heatsink thermal interface media is not reusable and must be replaced if the heatsink is removed from the processor after it has been installed.

- ⚠ CAUTION:** To prevent possible server overheating, always populate processor socket 2 with a processor and a heatsink or a processor socket cover and a heatsink blank.

- ⚠ CAUTION:** To avoid thermal shutdown, all fans must be installed in a dual processor configuration.

- 📝 IMPORTANT:** Processor socket 1 must be populated at all times or the server does not function.

To remove the processor:

1. Power down the server (on page 25).
2. Remove all power:
 - a. Disconnect each power cord from the power source.
 - b. Disconnect each power cord from the server.

3. Extend the server from the rack (on page 26).
4. Remove the access panel ("Access panel" on page 27).
5. Remove the heatsink ("Heatsink" on page 49).
6. Open each of the processor locking levers in the order indicated, and then open the processor retaining bracket.

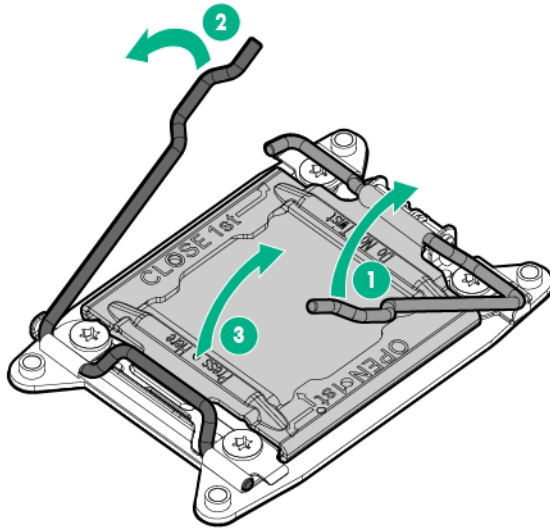

7. Remove the processor from the processor retaining bracket.

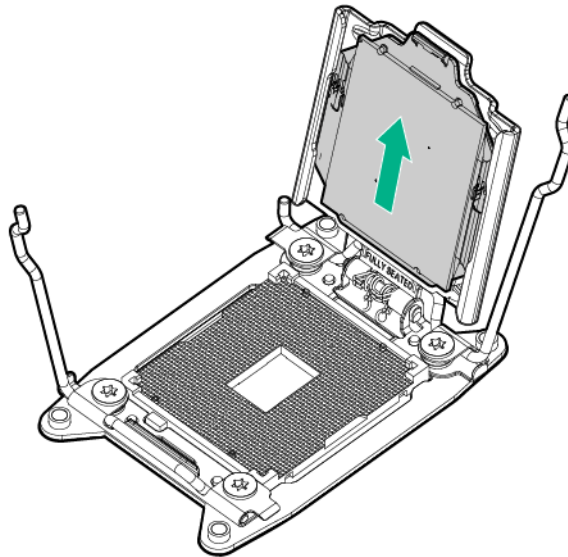

CAUTION: To avoid damage to the processor, do not touch the bottom of the processor, especially the contact area.

To replace the component:

1. Install the processor. Verify that the processor is fully seated in the processor retaining bracket by visually inspecting the processor installation guides on either side of the processor. **THE PINS ON THE SYSTEM BOARD ARE VERY FRAGILE AND EASILY DAMAGED.**

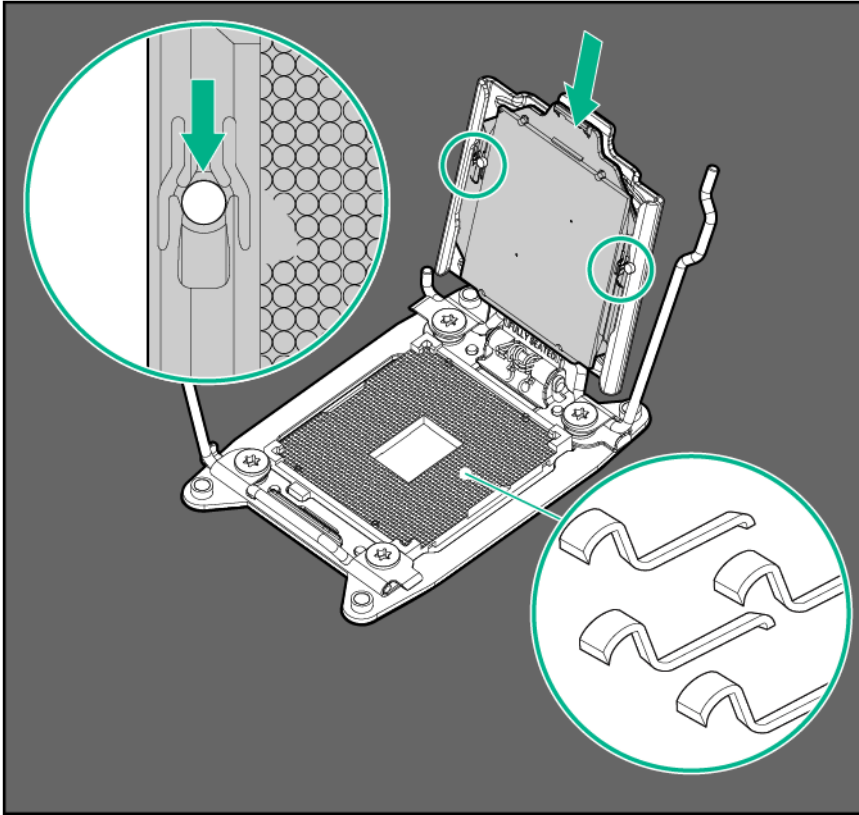

⚠ CAUTION: THE PINS ON THE SYSTEM BOARD ARE VERY FRAGILE AND EASILY DAMAGED. To avoid damage to the system board, do not touch the processor or the processor socket contacts.

2. Close the processor retaining bracket. When the processor is installed properly inside the processor retaining bracket, the processor retaining bracket clears the flange on the front of the socket.

⚠ CAUTION: Do not press down on the processor. Pressing down on the processor may cause damage to the processor socket and the system board. Press only in the area indicated on the processor retaining bracket.

3. Press and hold the processor retaining bracket in place, and then close each processor locking lever. Press only in the area indicated on the processor retaining bracket.

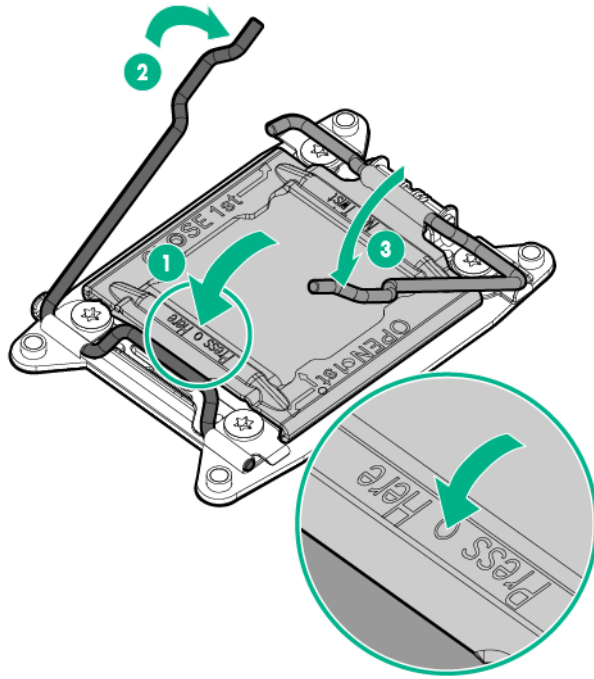

4. Remove the thermal interface protective cover from the heatsink.

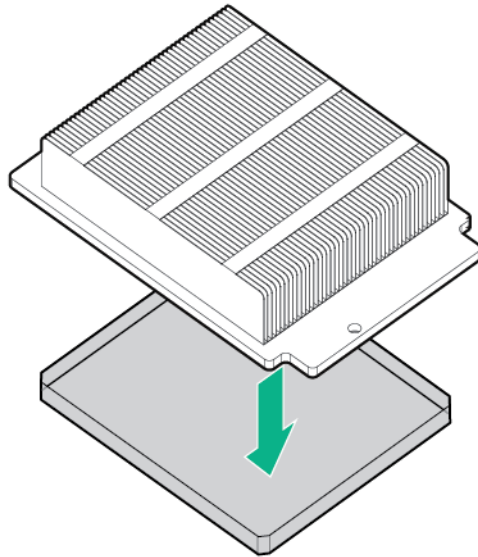

5. Install the heatsink, ensuring the alignment bracket aligns on the front of the heatsink.

- o Caged heatsink

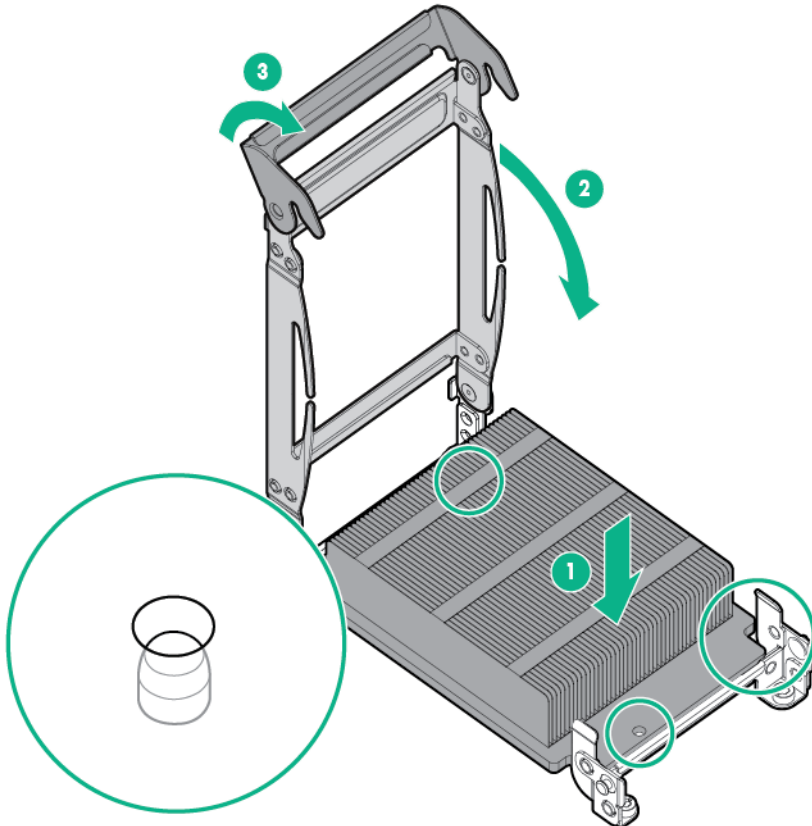

- o Screw-down heatsink

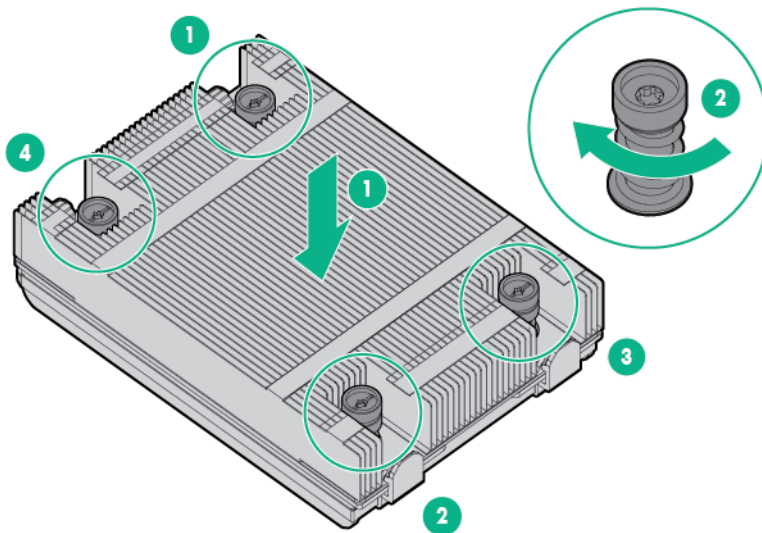

6. Install the access panel ("[Access panel](#)" on page 27).
7. Slide the server into the rack.
8. Connect each power cord to the server.
9. Connect each power cord to the power source.
10. Power up the server.

System battery

If the server no longer automatically displays the correct date and time, you may need to replace the battery that provides power to the real-time clock. Under normal use, battery life is 5 to 10 years.



WARNING: The computer contains an internal lithium manganese dioxide, a vanadium pentoxide, or an alkaline battery pack. A risk of fire and burns exists if the battery pack is not properly handled. To reduce the risk of personal injury:

- Do not attempt to recharge the battery.
- Do not expose the battery to temperatures higher than 60°C (140°F).
- Do not disassemble, crush, puncture, short external contacts, or dispose of in fire or water.
- Replace only with the spare designated for this product.

To remove the component:

1. Power down the server (on page 25).
2. Remove all power:
 - a. Disconnect each power cord from the power source.
 - b. Disconnect each power cord from the server.
3. Extend or remove the server from the rack ("[Extend the server from the rack](#)" on page 26).
4. Remove the access panel ("[Access panel](#)" on page 27).
5. If installed, remove the FBWC capacitor pack ("[FBWC capacitor pack](#)" on page 41).
6. Locate the battery on the system board ("[System board components](#)" on page 78).
7. Remove the battery.

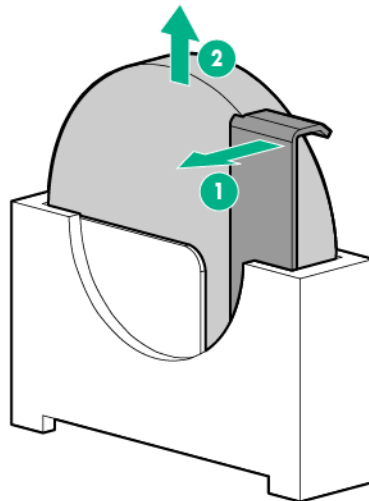

IMPORTANT: Replacing the system board battery resets the system ROM to its default configuration. After replacing the battery, reconfigure the system through RBSU.

To replace the component, reverse the removal procedure.

For more information about battery replacement or proper disposal, contact an authorized reseller or an authorized service provider.

System board

To remove the component:



IMPORTANT: Be sure you are using the correct spare part. The HPE ProLiant DL360p Gen8 Server ships with one of two different system boards that each use specific processors and heatsinks. To identify the proper system board spare part number, see the white label on the system board that shipped with the server.

1. Power down the server (on page 25).
2. Remove all power:
 - a. Disconnect each power cord from the power source.
 - b. Disconnect each power cord from the server.
3. Remove the server from the rack.
4. Remove the access panel ("Access panel" on page 27).
5. Remove all power supplies ("AC power supply" on page 29).
6. If installed, remove the FBWC capacitor pack ("FBWC capacitor pack" on page 41).
7. Remove the air baffle ("Air baffle" on page 45).



CAUTION: To prevent damage to the server or expansion boards, power down the server and remove all AC power cords before removing or installing the PCI riser cage.

8. Remove the PCI riser cage ("PCI riser cage" on page 46).
9. Remove the fans ("Fan module" on page 39).
10. Disconnect all cables connected to the system board ("System board components" on page 78). For more information, see "Cabling (on page 63)."
11. Remove the cache module ("Cache module" on page 41).
12. Remove the FlexibleLOM ("FlexibleLOM" on page 43).
13. Remove all DIMMs ("DIMMs" on page 48).
14. Remove the heatsink ("Heatsink" on page 49).
15. Remove the processor ("Processor" on page 52).
16. Remove the failed system board.

The server may look different than the one shown in the following illustration, depending on the server model.

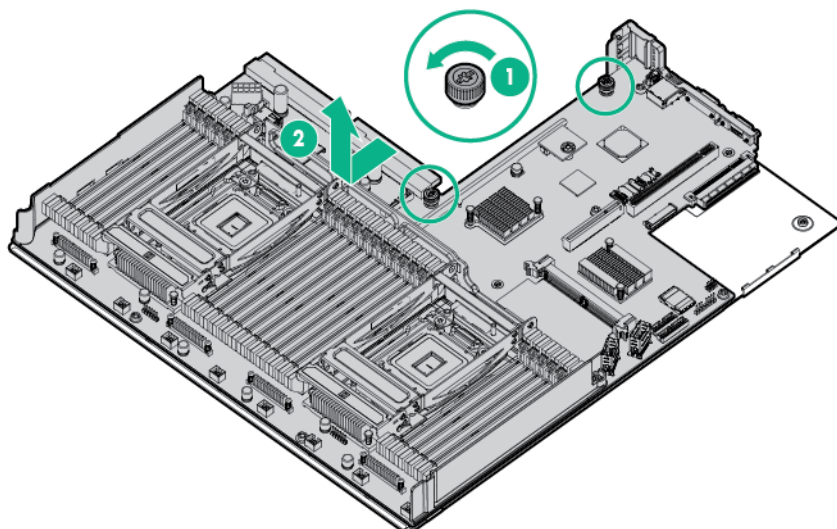

To replace the component:

1. Align the system board on the tray, and tighten the thumbscrew to secure it.

The server may look different than the one shown in the following illustration, depending on the server model.

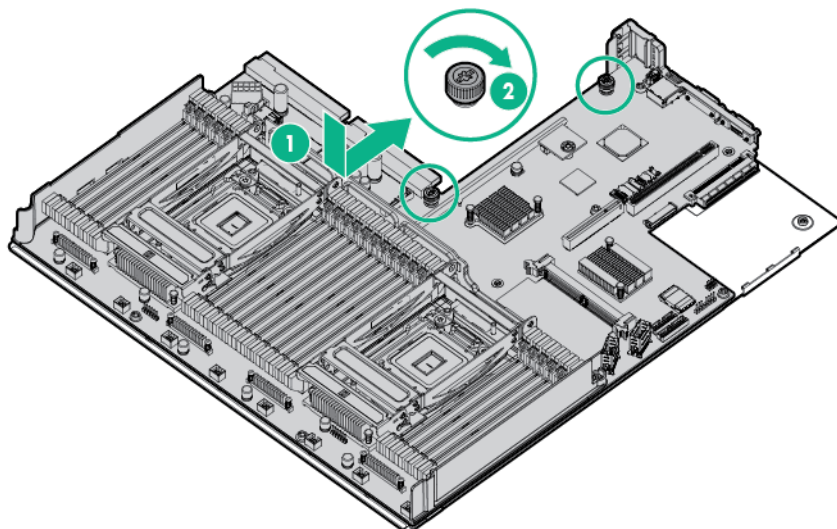

2. Open each of the processor locking levers in the order indicated, and then open the processor retaining bracket.

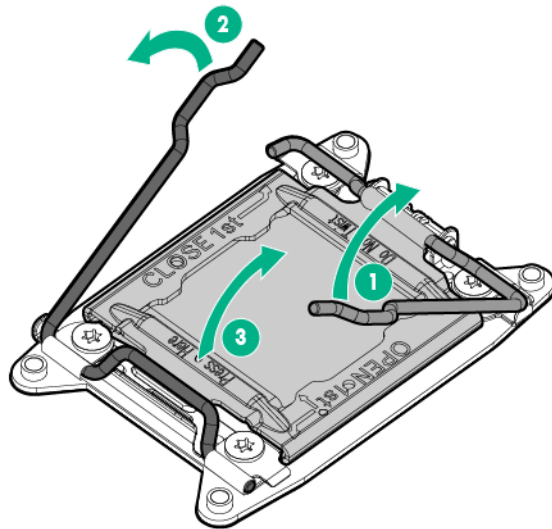

3. Install the processor. Verify that the processor is fully seated in the processor retaining bracket by visually inspecting the processor installation guides on either side of the processor. **THE PINS ON THE SYSTEM BOARD ARE VERY FRAGILE AND EASILY DAMAGED.**

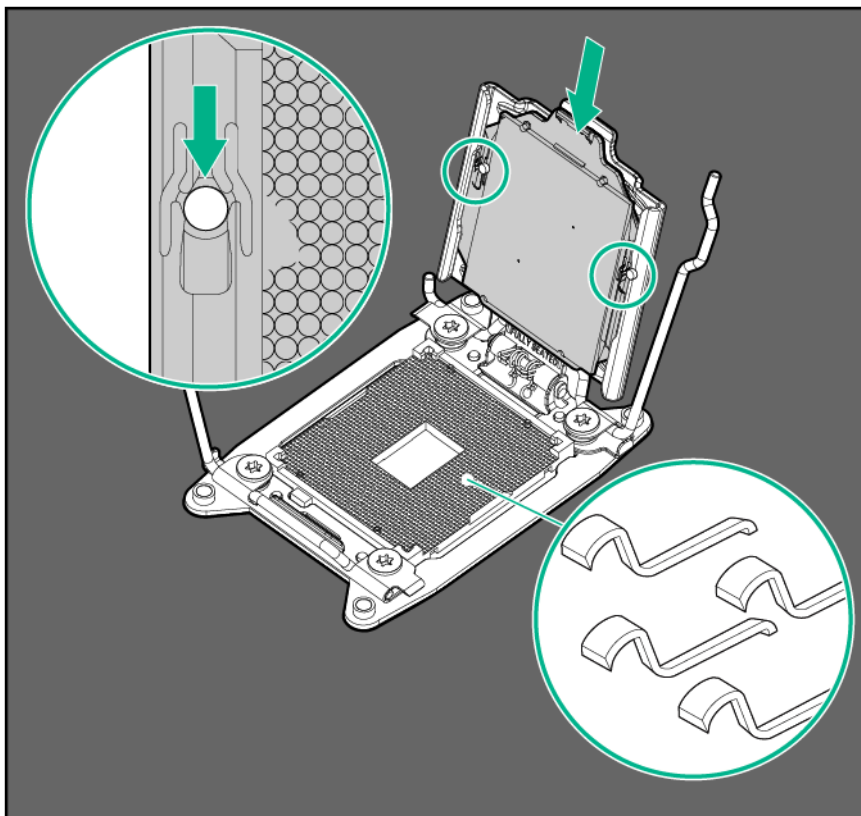

CAUTION: THE PINS ON THE SYSTEM BOARD ARE VERY FRAGILE AND EASILY DAMAGED. To avoid damage to the system board, do not touch the processor or the processor socket contacts.

4. Close the processor retaining bracket. When the processor is installed properly inside the processor retaining bracket, the processor retaining bracket clears the flange on the front of the socket.

CAUTION: Do not press down on the processor. Pressing down on the processor may cause damage to the processor socket and the system board. Press only in the area indicated on the processor retaining bracket.

5. Press and hold the processor retaining bracket in place, and then close each processor locking lever. Press only in the area indicated on the processor retaining bracket.

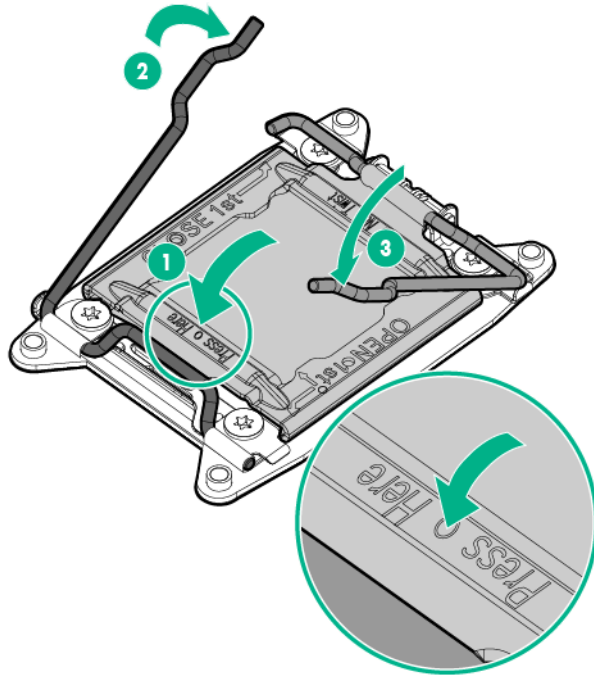

6. Install the processor socket cover onto the processor socket of the failed system board.
7. Clean the old thermal grease from the heatsink and the top of the processor with the alcohol swab. Allow the alcohol to evaporate before continuing.
8. Apply all the grease to the top of the processor in the following pattern to ensure even distribution.

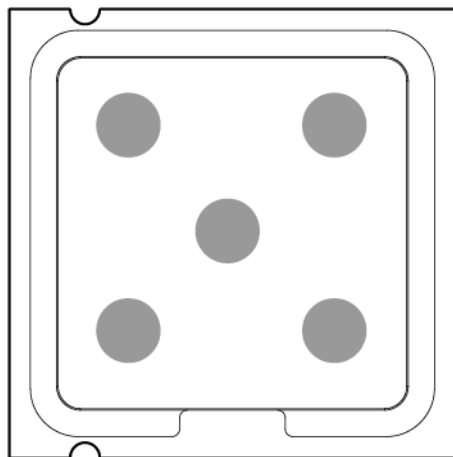

9. Install all components removed from the failed system board.
10. Install the access panel ("[Access panel](#)" on page 27).
11. Slide the server into the rack.

12. Connect each power cord to the server.
13. Connect each power cord to the power source.
14. Power up the server.



IMPORTANT: Install all components with the same configuration that was used on the failed system board.

After you replace the system board, you must re-enter the server serial number and the product ID.

1. During the server startup sequence, press the **F9** key to access RBSU.
2. Select the **Advanced Options** menu.
3. Select **Service Options**.
4. Select **Serial Number**. The following warning appears:
Warning: The serial number should ONLY be modified by qualified service personnel. This value should always match the serial number located on the chassis.
5. Press the **Enter** key to clear the warning.
6. Enter the serial number and press the **Enter** key.
7. Select **Product ID**. The following warning appears:
Warning: The Product ID should ONLY be modified by qualified service personnel. This value should always match the Product ID located on the chassis.
8. Enter the product ID and press the **Enter** key.
9. Press the **Esc** key to close the menu.
10. Press the **Esc** key to exit RBSU.
11. Press the **F10** key to confirm exiting RBSU. The server automatically reboots.

HP Trusted Platform Module

The TPM is not a customer-removable part.



CAUTION: Any attempt to remove an installed TPM from the system board breaks or disfigures the TPM security rivet. Upon locating a broken or disfigured rivet on an installed TPM, administrators should consider the system compromised and take appropriate measures to ensure the integrity of the system data.

If you suspect a TPM board failure, leave the TPM installed and remove the system board. Contact a Hewlett Packard Enterprise authorized service provider for a replacement system board and TPM board.

Cabling

Cabling overview

This section provides guidelines that help you make informed decisions about cabling the server and hardware options to optimize performance.

For information on cabling peripheral components, refer to the white paper on high-density deployment at the Hewlett Packard Enterprise website (<http://www.hpe.com/products/servers/platforms>).



CAUTION: When routing cables, always be sure that the cables are not in a position where they can be pinched or crimped.

Hard drive backplane cabling

The server ships with one hard drive backplane that supports up to 10 hard drives.

The server may look different than the one shown in the following illustrations, depending on the server model.

- SFF

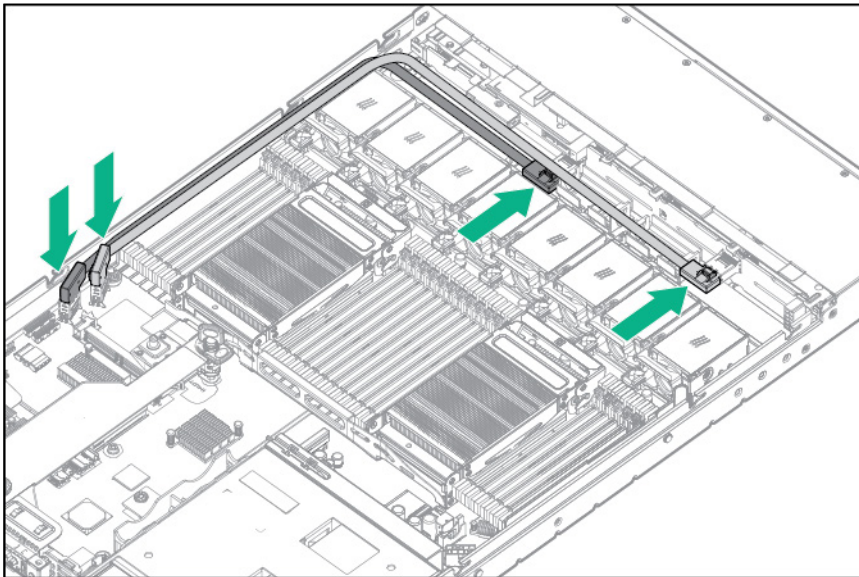

- LFF

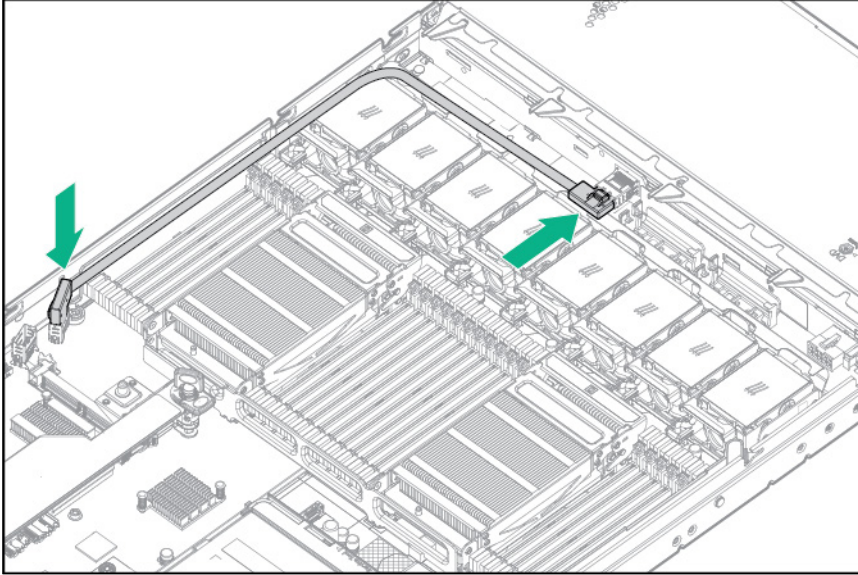

FBWC capacitor pack cabling

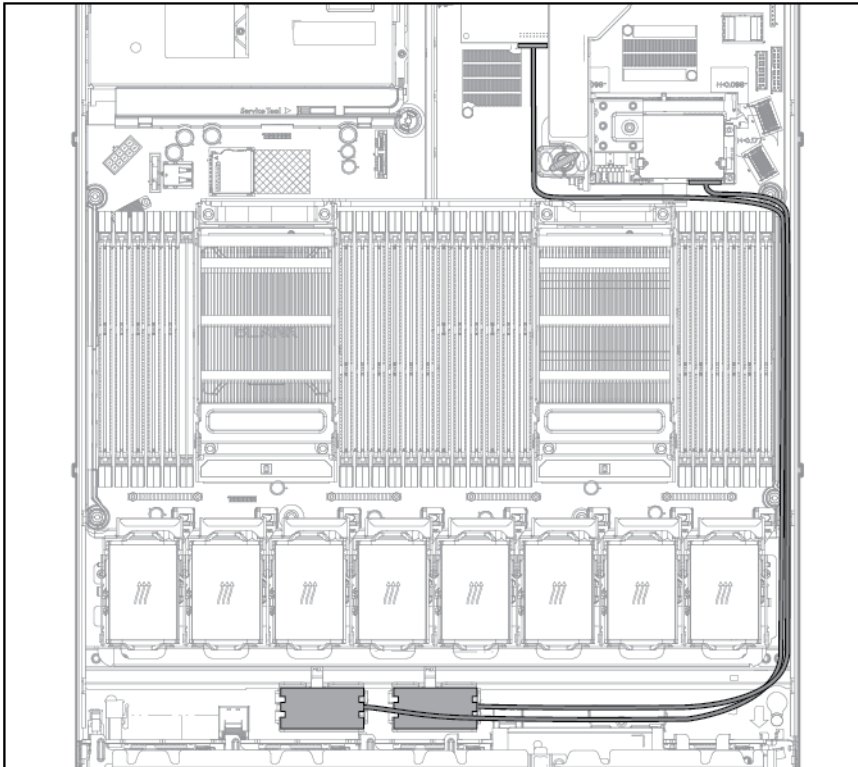

The second (left) capacitor pack cable connects to an optional Smart Array expansion board.

DVD-ROM and DVD-RW drive cabling

The server may look different than the one shown in the following illustration, depending on the server model.

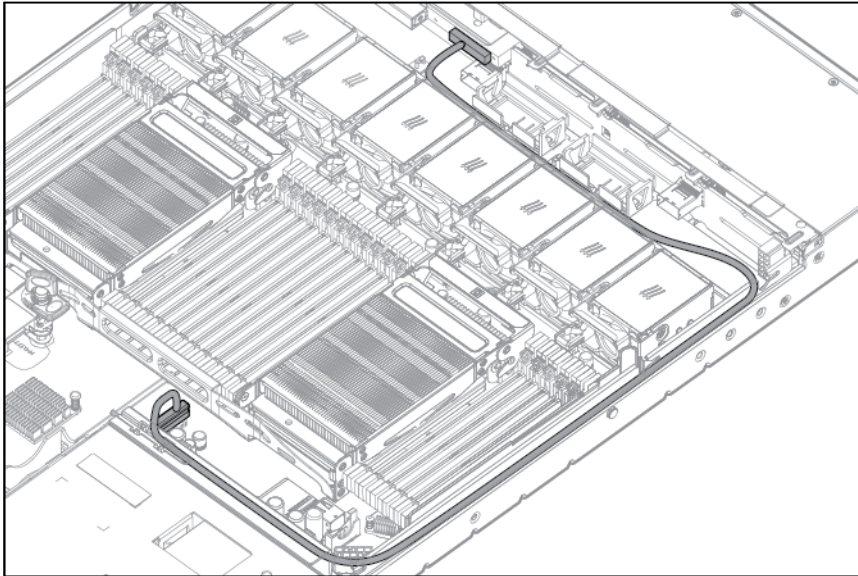

Chipset SATA cable option

With the chipset SATA cable option, the chipset SATA controller can be used with a single SATA hard drive that is installed in one hard drive bay of the SFF or LFF hard drive cage.

- When using the chipset SATA configuration, the following conditions apply:
 - The 10 SFF drive configuration does not support the chipset SATA option.
 - Only drive bay 1 is enabled. The remaining drive bays are disabled.
 - The optical bay is disabled because the chipset SATA controller port on the system board is redirected from the optical bay to the drive cage.
 - Hard drive status LEDs are not supported.
 - Hard drive thermal status monitoring is not supported.
 - Hot-plug operation is not supported.
- Because only one drive bay is enabled, all remaining drives can be removed.

For proper thermal cooling, install blanks in all bays that do not have a drive installed. Order a sufficient number of 6.35-cm (2.5-in) or 8.89-cm (3.5-in) hard drive blank option kits from a Hewlett Packard Enterprise authorized reseller. For more information, see the server maintenance and service guide.

The standard SATA driver is included with supported operating systems. No additional driver is required.

⚠ WARNING: Eliminate the risk of electric shock by removing all AC power from the system before installing or replacing any non-hot-plug hardware option. Disconnect all power cords to completely remove power from the server.

⚠ WARNING: To reduce the risk of personal injury from hot surfaces, allow the drives and the internal system components to cool before touching them.

To install the component:

1. Power down the server (on page 25).

2. Remove all power:
 - a. Disconnect each power cord from the power source.
 - b. Disconnect each power cord from the server.
3. Extend the server from the rack (on page 26).
4. Remove the access panel ("Access panel" on page 27).
5. Disconnect any SAS cables from the hard drive cage and either the embedded SAS controller or an optional SAS controller. Do not disconnect the power cable.
Remove two SAS cables from an SFF configuration, or one cable from an LFF configuration.
The server may look different than the one shown in the following illustrations, depending on the server model.

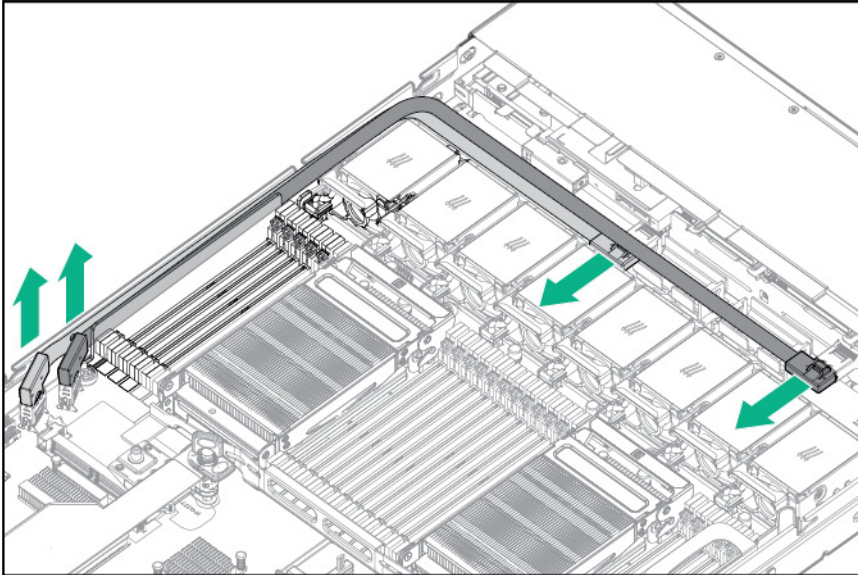

6. Disconnect the SATA cable from the optical drive and the SATA connector on the system board. The optical bay is disabled with the chipset SATA cable option.

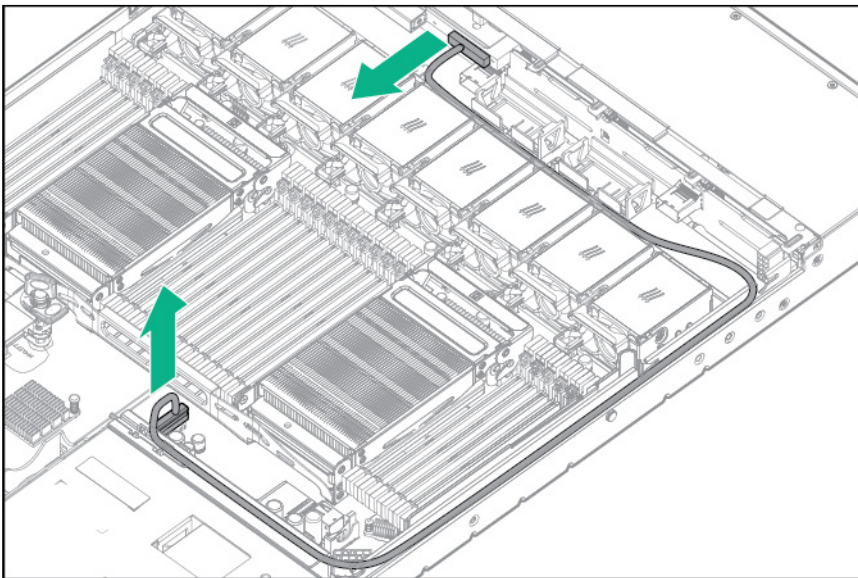

7. Connect the chipset SATA cable:

- a. Connect the chipset SATA cable connector to the chipset SATA controller port on the system board. The chipset SATA connector on the SATA cable is narrower than the chipset SATA controller port header on the system board.
- b. Connect the remaining chipset SATA cable connector to the SATA header on the hard drive cage.

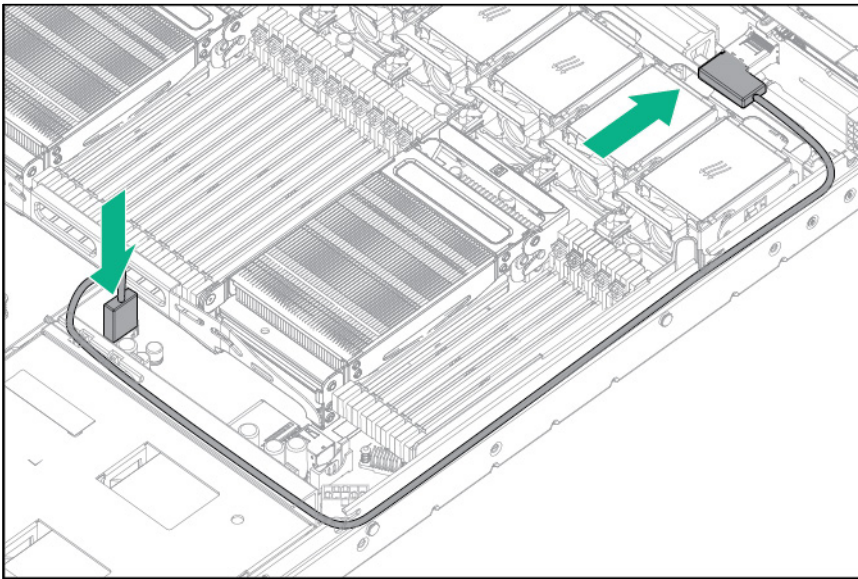

8. Clip the cable to the power supply air baffle when routing it along the edge of the system board.

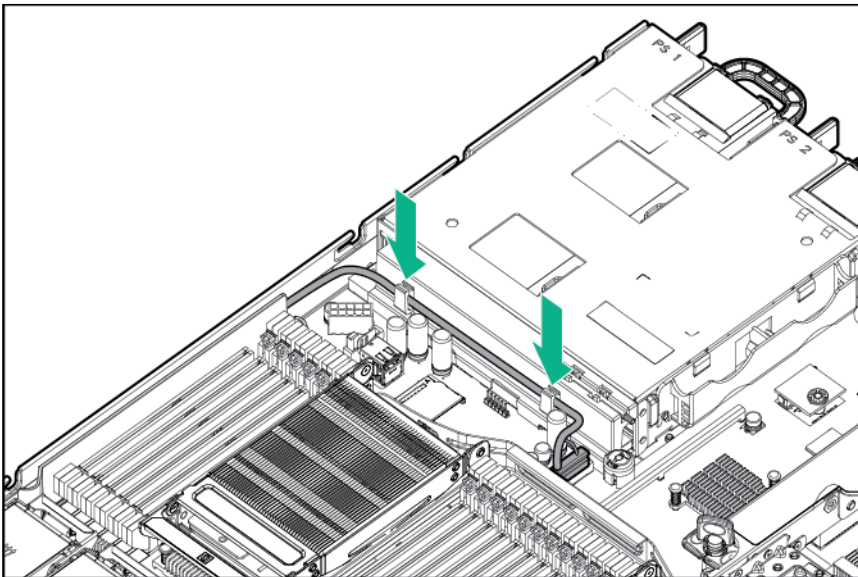

9. Coil the cables behind the hard drive backplane to minimize airflow impact.
10. Install the access panel ("[Access panel](#)" on page 27).
11. Install the server into the rack.
12. Remove any installed hard drives ("[Hot-plug drive](#)" on page 28).
13. Install a SATA hard drive in hard drive bay 1.
14. Install hard drive blanks in any empty hard drive bays.
15. Connect each power cord to the server.
16. Connect each power cord to the power source.
17. Power up the server.

18. Using the HPE ROM-Based Setup Utility (on page 70), disable the embedded P420i SAS storage controller, if necessary.

Diagnostic tools

Troubleshooting resources

The *ProLiant Gen8 Troubleshooting Guide, Volume I: Troubleshooting* provides procedures for resolving common problems and comprehensive courses of action for fault isolation and identification, issue resolution, and software maintenance on ProLiant servers and server blades. To view the guide, select a language:

- English (http://www.hpe.com/support/Gen9_TSG_en)
- French (http://www.hpe.com/support/Gen9_TSG_fr)
- Spanish (http://www.hpe.com/support/Gen9_TSG_es)
- German (http://www.hpe.com/support/Gen9_TSG_de)
- Japanese (http://www.hpe.com/support/Gen9_TSG_ja)
- Simplified Chinese (http://www.hpe.com/support/Gen9_TSG_zh_cn)

The *ProLiant Gen8 Troubleshooting Guide, Volume II: Error Messages* provides a list of error messages and information to assist with interpreting and resolving error messages on ProLiant servers and server blades. To view the guide, select a language:

- English (http://www.hpe.com/support/Gen9_EMG_en)
- French (http://www.hpe.com/support/Gen9_EMG_fr)
- Spanish (http://www.hpe.com/support/Gen9_EMG_es)
- German (http://www.hpe.com/support/Gen9_EMG_de)
- Japanese (http://www.hpe.com/support/Gen9_EMG_ja)
- Simplified Chinese (http://www.hpe.com/support/Gen9_EMG_zh_cn)

HPE Insight Diagnostics

The Insight Diagnostics is a proactive server management tool, available in both offline and online versions, that provides diagnostics and troubleshooting capabilities to assist IT administrators who verify server installations, troubleshoot problems, and perform repair validation.

The Insight Diagnostics Offline Edition performs various in-depth system and component testing while the OS is not running. To run this utility, boot the server using Intelligent Provisioning.

The Insight Diagnostics Online Edition is a web-based application that captures system configuration and other related data needed for effective server management. Available in Microsoft Windows and Linux versions, the utility helps to ensure proper system operation.

For more information or to download the utility, see the Hewlett Packard Enterprise website (<http://www.hpe.com/servers/diags>). The Insight Diagnostics Online Edition is also available in the SPP.

HPE Insight Diagnostics survey functionality

HPE Insight Diagnostics (on page 69) provides survey functionality that gathers critical hardware and software information on ProLiant servers.

This functionality supports operating systems that are supported by the server. For operating systems supported by the server, see the Hewlett Packard Enterprise website (<http://www.hpe.com/info/supportos>).

If a significant change occurs between data-gathering intervals, the survey function marks the previous information and overwrites the survey data files to reflect the latest changes in the configuration.

Survey functionality is installed with every Intelligent Provisioning-assisted HPE Insight Diagnostics installation, or it can be installed through the SPP.

HPE ROM-Based Setup Utility

RBSU is a configuration utility embedded in HPE ProLiant servers that performs a wide range of configuration activities that can include the following:

- Configuring system devices and installed options
- Enabling and disabling system features
- Displaying system information
- Selecting the primary boot controller
- Configuring memory options
- Language selection

For more information on RBSU, see the *ROM-Based Setup Utility User Guide* on the Documentation CD or the RBSU Information Library (<http://www.hpe.com/info/rbsu/docs>).

Integrated Management Log

The IML records hundreds of events and stores them in an easy-to-view form. The IML timestamps each event with 1-minute granularity.

You can view recorded events in the IML in several ways, including the following:

- From within HPE SIM
- From within operating system-specific IML viewers:
 - For Windows: IML Viewer
 - For Linux: IML Viewer Application
- From within the HPE iLO web interface
- From within Insight Diagnostics ("[HPE Insight Diagnostics](#)" on page 69)

USB support and functionality

USB support

Hewlett Packard Enterprise provides both standard USB 2.0 support and legacy USB 2.0 support. Standard support is provided by the OS through the appropriate USB device drivers. Before the OS loads, Hewlett Packard Enterprise provides support for USB devices through legacy USB support, which is enabled by default in the system ROM.

Legacy USB support provides USB functionality in environments where USB support is not available normally. Specifically, Hewlett Packard Enterprise provides legacy USB functionality for the following:

- POST

- RBSU
- Diagnostics
- DOS
- Operating environments which do not provide native USB support

Internal USB functionality

An internal USB connector is available for use with security key devices and USB drive keys. This solution provides for use of a permanent USB key installed in the internal connector, avoiding issues of clearance on the front of the rack and physical access to secure data.

Component identification

Front panel components

- 8 SFF

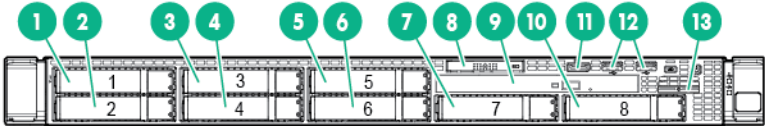

Item	Description
1	SAS/SATA/SSD drive bay 1
2	SAS/SATA/SSD drive bay 2
3	SAS/SATA/SSD drive bay 3
4	SAS/SATA/SSD drive bay 4
5	SAS/SATA/SSD drive bay 5
6	SAS/SATA/SSD drive bay 6
7	SAS/SATA/SSD drive bay 7
8	Systems Insight Display
9	DVD-ROM drive (optional)
10	SAS/SATA/SSD drive bay 8
11	Front video connector (front video port adapter required)
12	USB connectors (2)
13	Serial number tab

- 4 LFF



Item	Description
1	SAS/SATA/SSD drive bay 1
2	DVD-ROM drive (optional)
3	SAS/SATA/SSD drive bay 2
4	Serial number tab
5	SAS/SATA/SSD drive bay 3
6	Systems Insight Display
7	SAS/SATA/SSD drive bay 4
8	Front video connector (front video port adapter required)
9	USB connectors (2)

- 10 SFF

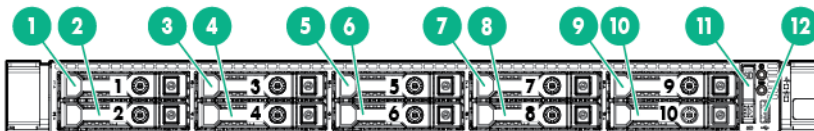

Item	Description
1	SAS/SATA/SSD drive bay 1
2	SAS/SATA/SSD drive bay 2
3	SAS/SATA/SSD drive bay 3
4	SAS/SATA/SSD drive bay 4
5	SAS/SATA/SSD drive bay 5
6	SAS/SATA/SSD drive bay 6

Item	Description
7	SAS/SATA/SSD drive bay 7
8	SAS/SATA/SSD drive bay 8
9	SAS/SATA/SSD drive bay 9
10	SAS/SATA/SSD drive bay 10
11	Systems Insight Display
12	USB connector

Front panel LEDs and buttons

- 8 SFF or 4 LFF

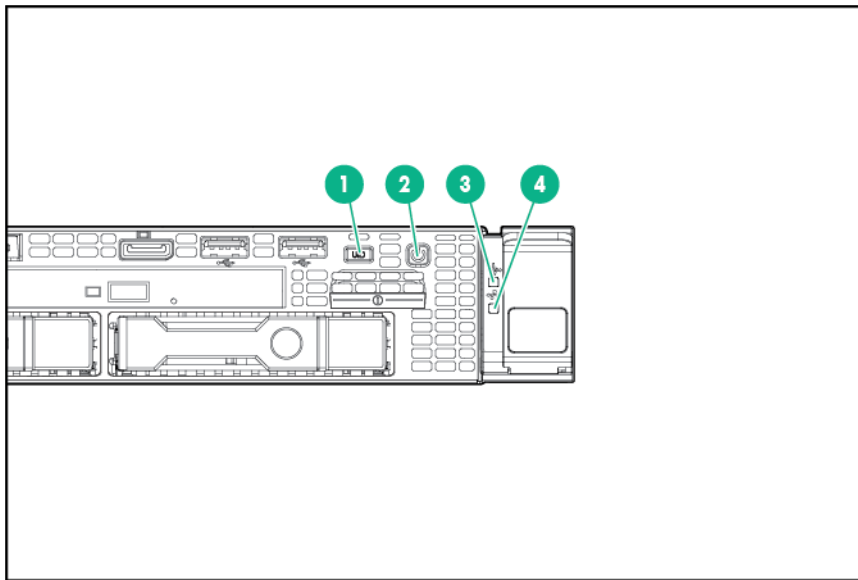

Item	Description	Status
1	UID button/LED	Solid blue = Activated Flashing blue (1 Hz/cycle per sec) = Remote management or firmware upgrade in progress Off = Deactivated
2	Power On/Standby button and system power LED	Solid green = System on Flashing green (1 Hz/cycle per sec) = Performing power on sequence Solid amber = System in standby Off = No power present*
3	Health LED	Solid green = Normal Flashing amber = System degraded Flashing red (1 Hz/cycle per sec) = System critical Fast-flashing red (4 Hz/cycles per sec) = Power fault**
4	NIC status LED	Solid green = Link to network Flashing green (1 Hz/cycle per sec) = Network active Off = No network activity

*Facility power is not present, power cord is not attached, no power supplies are installed, power supply failure has occurred, or the power button cable is disconnected.

**To identify components in a degraded or critical state, see the Systems Insight Display LEDs (on page 80), check iLO/BIOS logs, and reference the server troubleshooting guide.

- 10 SFF

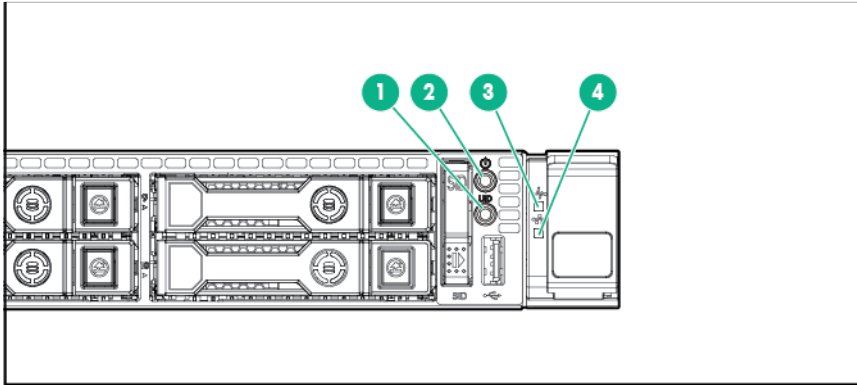

Item	Description	Status
1	UID button/LED	Solid blue = Activated Flashing blue (1 Hz/cycle per sec) = Remote management or firmware upgrade in progress Off = Deactivated
2	Power On/Standby button and system power LED	Solid green = System on Flashing green (1 Hz/cycle per sec) = Performing power on sequence Solid amber = System in standby Off = No power present*
3	Health LED	Solid green = Normal Flashing amber = System degraded Flashing red (1 Hz/cycle per sec) = System critical Fast-flashing red (4 Hz/cycles per sec) = Power fault**
4	NIC status LED	Solid green = Link to network Flashing green (1 Hz/cycle per sec) = Network active Off = No network activity

*Facility power is not present, power cord is not attached, no power supplies are installed, power supply failure has occurred, or the power button cable is disconnected.

**To identify components in a degraded or critical state, see the Systems Insight Display LEDs (on page 80), check iLO/BIOS logs, and reference the server troubleshooting guide.

Rear panel components

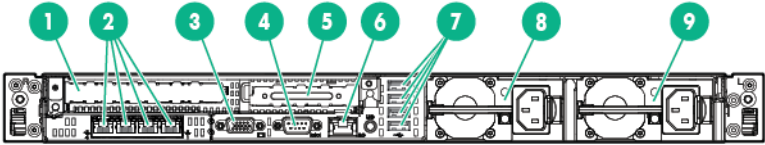

Item	Description
1	Slot 2 PCIe 3.0 x16 (full height/half length)
2	FlexibleLOM ports (Shown: 4x1Gb / Optional: 2x10Gb)
3	Video connector
4	Serial connector
5	Slot 1 PCIe 3.0 x8 (low profile)
6	iLO management port
7	USB connectors (4)
8	Power supply bay 2
9	Power supply bay 1

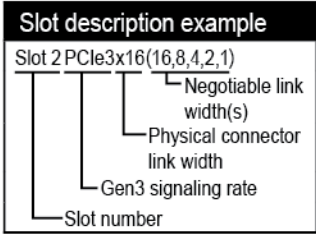

Rear panel LEDs and buttons

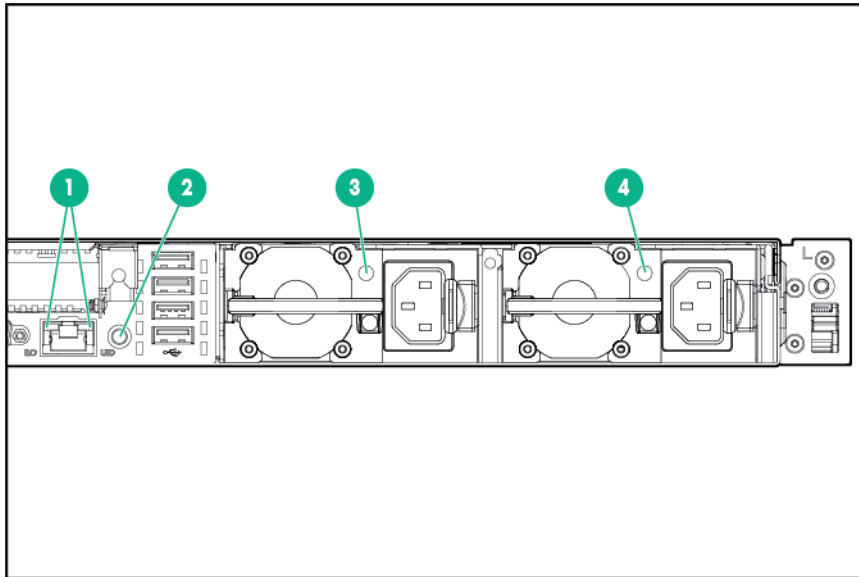

Item	Description	Status
1L	HPE iLO/standard NIC activity LED	Solid green = Activity exists. Flashing green = Activity exists. Off = No activity exists.
1R	HPE iLO/standard NIC link LED	Solid green = Link exists. Off = No link exists.
2	UID button/LED	Solid blue = Identification is activated. Flashing blue = System is being managed remotely. Off = Identification is deactivated.
3	Power supply 2 LED	Solid green = Normal Off = One or more of the following conditions exists: <ul style="list-style-type: none"> • AC power unavailable • Power supply failed • Power supply in standby mode • Power supply exceeded current limit
4	Power supply 1 LED	Solid green = Normal Off = One or more of the following conditions exists: <ul style="list-style-type: none"> • AC power unavailable • Power supply failed • Power supply in standby mode • Power supply exceeded current limit

System board components

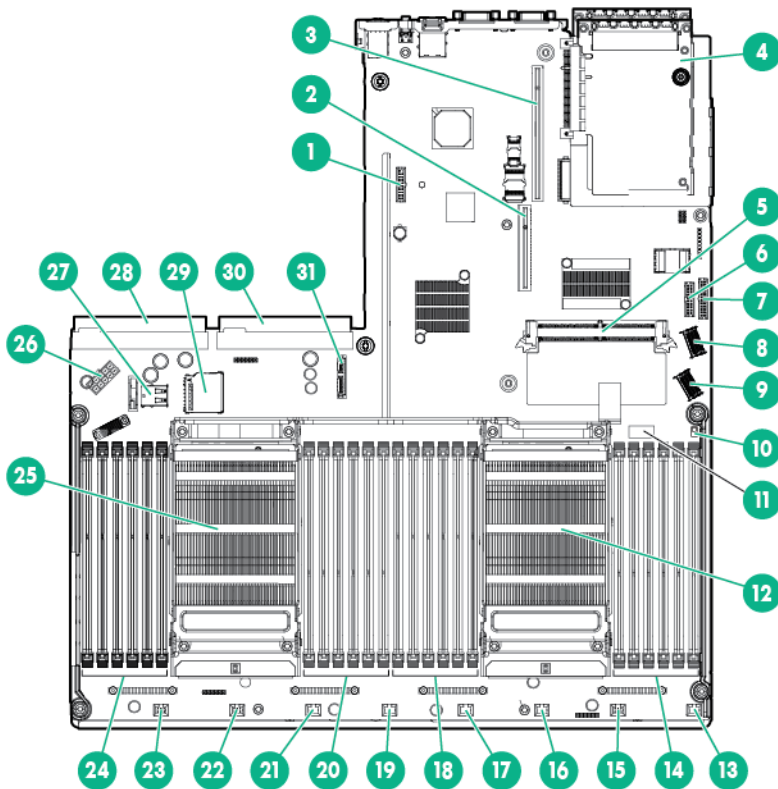

Item	Description
1	TPM connector
2	PCIe x8 riser connector
3	PCIe x16 riser connector
4	FlexibleLOM
5	SAS cache module connector
6	Front LED/Power cable connector
7	Front USB/Video cable connector
8	SAS connector B (Drives 5–8)
9	SAS connector A (drives 1–4)
10	NMI jumper
11	System maintenance switch
12	Processor 1
13	Fan module 8 connector
14	Processor 1 DIMM slots
15	Fan module 7 connector
16	Fan module 6 connector
17	Fan module 5 connector
18	Processor 1 DIMM slots
19	Fan module 4 connector
20	Processor 2 DIMM slots
21	Fan module 3 connector
22	Fan module 2 connector

Item	Description
23	Fan module 1 connector
24	Processor 2 DIMM slots
25	Processor 2
26	Drive backplane power connector
27	Internal USB connector
28	Power supply connector 1
29	SD card slot
30	Power supply connector 2
31	Optical SATA connector

DIMM slots

DIMM slots are numbered sequentially (1 through 12) for each processor. The supported AMP modes use the letter assignments for population guidelines.

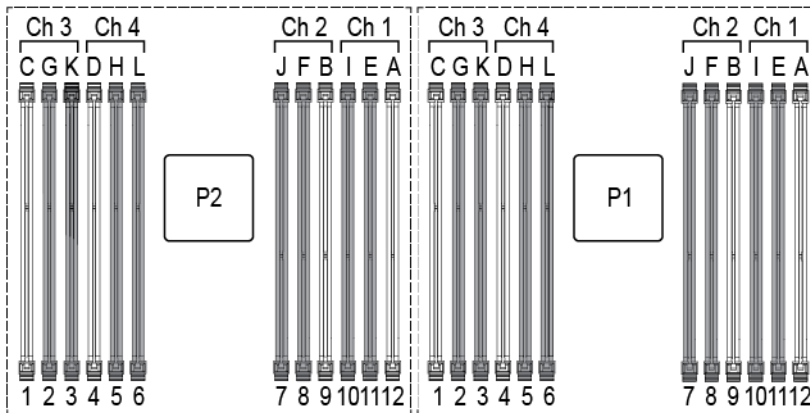

System maintenance switch

Position	Default	Function
S1	Off	Off = HPE iLO security is enabled. On = HPE iLO security is disabled.
S2	Off	Off = System configuration can be changed. On = System configuration is locked.
S3	Off	Reserved
S4	Off	Reserved
S5	Off	Off = Power-on password is enabled. On = Power-on password is disabled.
S6	Off	Off = No function On = ROM reads system configuration as invalid.
S7	—	Reserved
S8	—	Reserved

Position	Default	Function
S9	—	Reserved
S10	—	Reserved
S11	—	Reserved
S12	—	Reserved

To access the redundant ROM, set S1, S5, and S6 to on.

When the system maintenance switch position 6 is set to the On position, the system is prepared to erase all system configuration settings from both CMOS and NVRAM.

CAUTION: Clearing CMOS and/or NVRAM deletes configuration information. Be sure to properly configure the server or data loss could occur.

NMI jumper

The NMI jumper allows administrators to perform a memory dump before performing a hard reset. Crash dump analysis is an essential part of eliminating reliability problems, such as hangs or crashes in OSs, device drivers, and applications. Many crashes can freeze a system, requiring you to do a hard reset. Resetting the system erases any information that would support root cause analysis.

Systems running Microsoft® Windows® experience a blue-screen trap when the OS crashes. When this happens, Microsoft® recommends that system administrators perform an NMI event by temporarily shorting the NMI header with a jumper. The NMI event enables a hung system to become responsive again.

Systems Insight Display LEDs

The Systems Insight Display LEDs represent the system board layout. The display provides status for all internal LEDs and enables diagnosis with the access panel installed. To view the LEDs, access the Systems Insight Display.

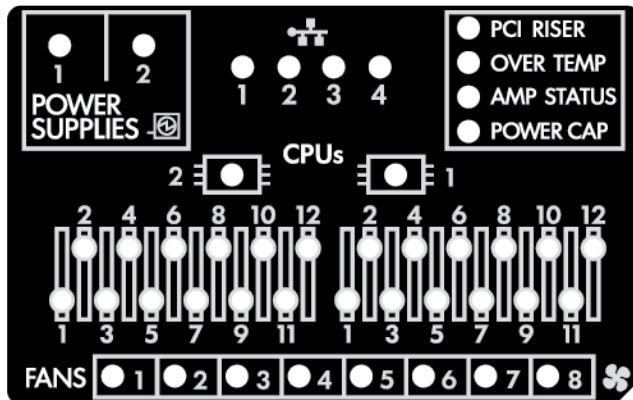

Description	Status
Processor LEDs	Off = Normal Amber = Failed processor
DIMM LEDs	Off = Normal Amber = Failed DIMM or configuration issue
Fan LEDs	Off = Normal Amber = Failed fan or missing fan

Description	Status
NIC LEDs	Off = No link to network Solid green = Network link Flashing green = Network link with activity If power is off, the front panel LED is not active. For status, see "Rear panel LEDs and buttons ("Rear panel components" on page 76, on page 77)."
Power supply LEDs	Off = Normal Amber = Failed power supply
PCI riser LED	Off = Normal Amber = Incorrectly installed PCI riser board
Over temp LED	Off = Normal Amber = High system temperature detected
AMP status LED	Off = Disabled Solid green = Advanced Memory Protection active Solid amber = Memory failure has occurred. Flashing amber = Invalid AMP memory configuration
Power cap LED	Off = System is in standby, or no cap is set. Solid green = Power cap applied

For more information, see "Systems Insight Display LED combinations (on page 81)."

Systems Insight Display LED combinations

When the health LED on the front panel illuminates either amber or red, the server is experiencing a health event. Combinations of illuminated Systems Insight Display LEDs, the system power LED, and the health LED indicate system status.

Systems Insight Display LED and color	Health LED	System power LED	Status
Processor (amber)	Red	Amber	One or more of the following conditions may exist: <ul style="list-style-type: none"> Processor in socket X has failed. Processor X is not installed in the socket. Processor X is unsupported. ROM detects a failed processor during POST.
Processor (amber)	Amber	Green	Processor in socket X is in a pre-failure condition.
DIMM (amber)	Red	Green	One or more DIMMs have failed.
DIMM (amber)	Amber	Green	DIMM in slot X is in a pre-failure condition.
Over temp (amber)	Amber	Green	The Health Driver has detected a cautionary temperature level.
Over temp (amber)	Red	Amber	The server has detected a hardware critical temperature level.
PCI riser (amber)	Red	Green	The PCI riser cage is not seated properly.
Fan (amber)	Amber	Green	One fan has failed or has been removed.
Fan (amber)	Red	Green	Two or more fans have failed or been removed.
Power supply (amber)	Red	Amber	One or more of the following conditions may exist: <ul style="list-style-type: none"> Only one power supply is installed and that power supply is in standby. Power supply fault

Systems Insight Display LED and color	Health LED	System power LED	Status
Power supply (amber)	Amber	Green	<ul style="list-style-type: none"> System board fault One or more of the following conditions may exist: <ul style="list-style-type: none"> Redundant power supply is installed and only one power supply is functional. AC power cord is not plugged into redundant power supply. Redundant power supply fault Power supply mismatch at POST or power supply mismatch through hot-plug addition
Power cap (off)	—	Amber	Standby
Power cap (green)	—	Flashing green	Waiting for power
Power cap (green)	—	Green	Power is available.



IMPORTANT: If more than one DIMM slot LED is illuminated, further troubleshooting is required. Test each bank of DIMMs by removing all other DIMMs. Isolate the failed DIMM by replacing each DIMM in a bank with a known working DIMM.

Device numbers

- 4 LFF configuration

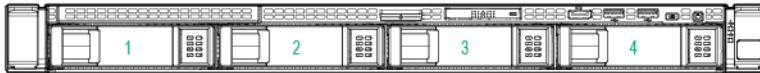

- 8 SFF configuration



- 10 SFF configuration



IMPORTANT: A cache module is required for a 10 SFF drive cage. Drives installed in a 10 SFF configuration do not function without a cache module.

For more information, see the server user guide.

Hot-plug drive LED definitions

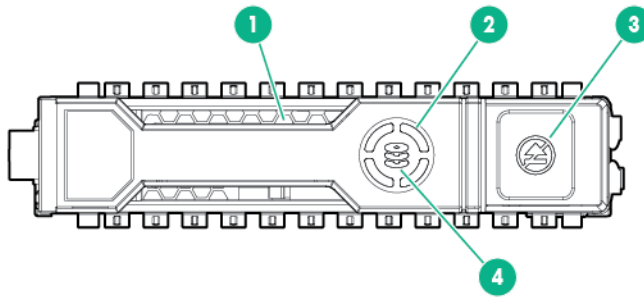

Item	LED	Status	Definition
1	Locate	Solid blue	The drive is being identified by a host application.
		Flashing blue	The drive carrier firmware is being updated or requires an update.
2	Activity ring	Rotating green	Drive activity
		Off	No drive activity
3	Do not remove	Solid white	Do not remove the drive. Removing the drive causes one or more of the logical drives to fail.
		Off	Removing the drive does not cause a logical drive to fail.
4	Drive status	Solid green	The drive is a member of one or more logical drives.
		Flashing green	The drive is rebuilding or performing a RAID migration, strip size migration, capacity expansion, or logical drive extension, or is erasing.
		Flashing amber/green	The drive is a member of one or more logical drives and predicts the drive will fail.
		Flashing amber	The drive is not configured and predicts the drive will fail.
		Solid amber	The drive has failed.
	Off	The drive is not configured by a RAID controller.	

Fan modules

- One-processor configuration

When only one processor is installed, be sure the fan blanks are always installed in bays 1 and 2 to ensure proper cooling.

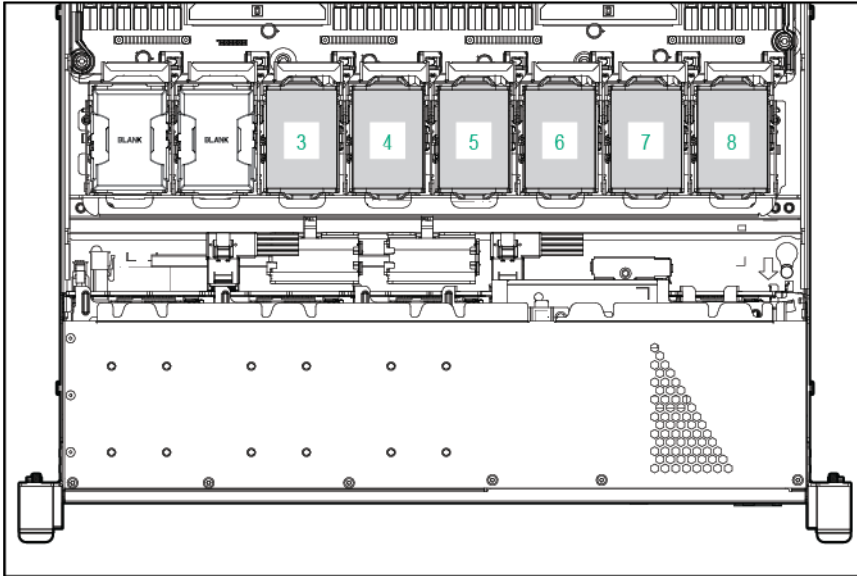

- Two-processor configuration

Install fans 1 and 2 only when processor 2 is installed. When only one processor is installed, always install the fan blanks.

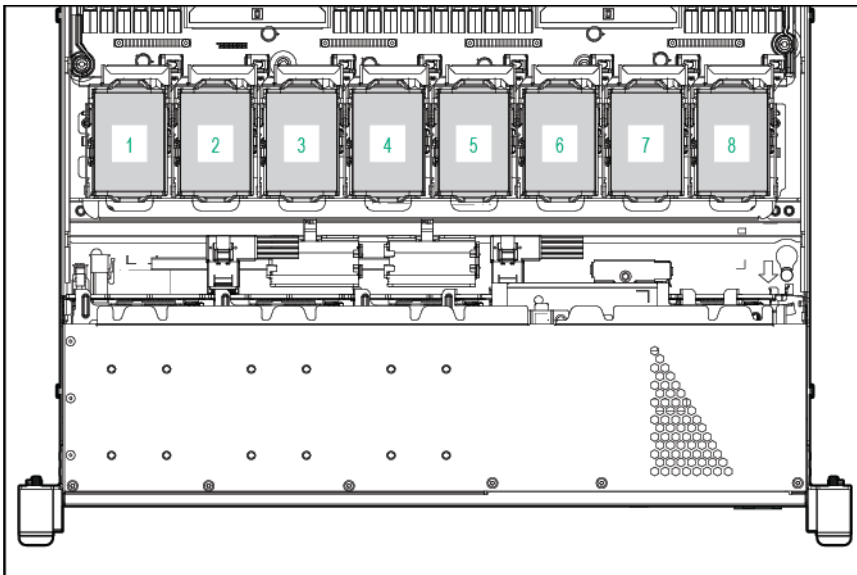

Storage and expansion diagram

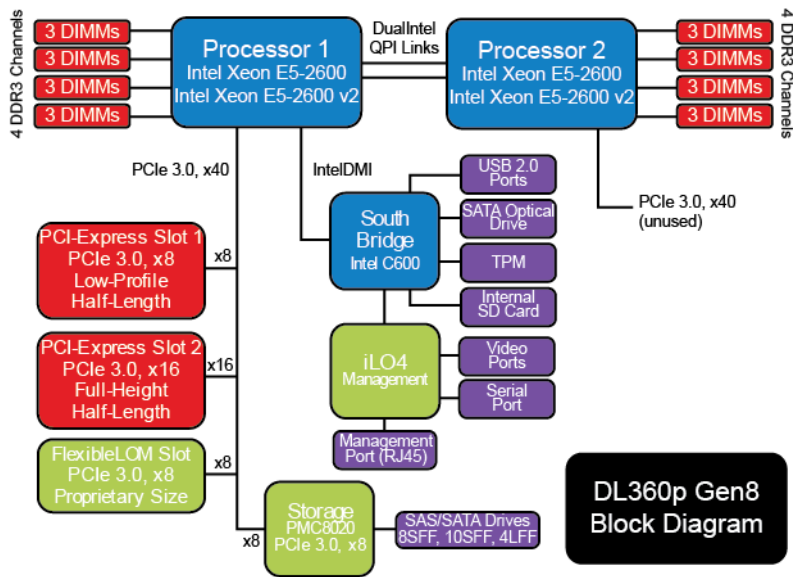

Specifications

Environmental specifications

Specification	Value
Temperature range*	—
Operating	10°C to 35°C (50°F to 95°F)
Non-operating	-30°C to 60°C (-22°F to 140°F)
Relative humidity (noncondensing)	—
Operating	10% to 90% 28°C (82.4°F), maximum wet bulb temperature
Non-operating	5% to 95% 38.7°C (101.7°F), maximum wet bulb temperature

* All temperature ratings shown are for sea level. An altitude derating of 1°C per 304.8 m (1.8°F per 1,000 ft) to 3048 m (10,000 ft) is applicable. No direct sunlight allowed.

Server specifications

Specification	Value
Height	4.32 cm (1.70 in)
Depth (chassis with SFF HDD cage)	69.85 cm (27.50 in)
Depth (chassis with LFF HDD cage)	74.67 cm (29.50 in)
Width	43.47 cm (17.11 in)
Weight (8 SFF: two processors, two power supplies, eight hard drives)	19.2 kg (42.33 lb)
Weight (10 SFF: two processors, two power supplies, ten hard drives)	19.185 kg (42.30 lb)
Weight (4 LFF: two processors, two power supplies, four hard drives)	20.7 kg (45.64 lb)

Power supply specifications

Depending on installed options, the server is configured with one of the following power supplies:

- HPE 460W Common Slot Gold Hot Plug Power Supply (92% efficiency) (on page [87](#))
- HPE 460W Common Slot Platinum Plus Hot Plug Power Supply (94% efficiency) (on page [87](#))
- HPE 500W Common Slot 277VAC Hot Plug Power Supply (94% efficiency) (on page [88](#))
- HPE 750W Common Slot 277VAC Hot Plug Power Supply (94% efficiency)
- HPE 750W Common Slot Titanium Hot Plug Power Supply (96% efficiency) (on page [88](#))
- HPE 750W Common Slot Gold Hot Plug Power Supply (92% efficiency) (on page [89](#))
- HPE 750W Common Slot Platinum Plus Hot Plug Power Supply (94% efficiency) (on page [89](#))
- HPE 750W Common Slot -48VDC Hot Plug Power Supply (94% efficiency) (on page [90](#))

- HPE 1200W Common Slot Platinum Plus Hot Plug Power Supply (94% efficiency) (on page 90)

For detailed power supply specifications, see the quickspecs on the Hewlett Packard Enterprise website (<http://www.hpe.com/info/Quickspecs-CommonSlotPowerSupplies>).

HPE 460W Common Slot Gold Hot Plug Power Supply (92% efficiency)

Specification	Value
Input requirements	
Rated input voltage	100 to 120 VAC, 200 to 240 VAC
Rated input frequency	50 Hz to 60 Hz
Rated input current	5.5 A at 100 VAC 2.6 A at 200 VAC
Rated input power	526 W at 100V AC input 505 W at 200V AC input
BTUs per hour	1794 at 100V AC input 1725 at 200V AC input
Power supply output	
Rated steady-state power	460 W at 100V to 120V AC input 460 W at 200V to 240V AC input
Maximum peak power	460 W at 100V to 120V AC input 460 W at 200V to 240V AC input

HPE 460W Common Slot Platinum Plus Hot Plug Power Supply (94% efficiency)

Specification	Value
Input requirements	
Rated input voltage	100 to 120 VAC, 200 to 240 VAC
Rated input frequency	50 Hz to 60 Hz
Rated input current	5.2 A at 100 VAC 2.5 A at 200 VAC
Rated input power	517 W at 100V AC input 496 W at 200V AC input
Btus per hour	1764 at 100V AC input 1694 at 200V AC input
Power supply output	
Rated steady-state power	460 W at 100V to 120V AC input 460 W at 200V to 240V AC input
Maximum peak power	460 W at 100V to 120V AC input 460 W at 200V to 240V AC input

HPE 500W Common Slot 277VAC Hot Plug Power Supply (94% efficiency)

Specification	Value
Input requirements	
Rated input voltage	200 V to 277 V AC
Rated input frequency	50 Hz–60 Hz
Rated input current	3.0 A at 200 V AC 2.0 A at 277 V AC
Rated input power	600 W at 200 V AC input 554 W at 277 V AC input
Btus per hour	1843 at 200 V AC input 1831 at 277 V AC input
Power supply output	
Rated steady-state power	500 W at 200 V AC to 277 V AC input
Maximum peak power	500 W at 200 V AC to 277 V AC input

HPE 750W Common Slot 277VAC Hot Plug Power Supply (94% efficiency)

Specification	Value
Input requirements	
Rated input voltage	200 V to 277 V AC
Rated input frequency	50 Hz–60 Hz
Rated input current	4.1 A at 200 V AC 3.0 A at 277 V AC
Rated input power	820 W at 200 V AC input 811 W at 277 V AC input
Btus per hour	2796 at 200 V AC input 2767 at 277 V AC input
Power supply output	
Rated steady-state power	750 W at 200 V AC to 277 V AC input
Maximum peak power	750 W at 200 V AC to 277 V AC input

HPE 750W Common Slot Titanium Hot Plug Power Supply (96% efficiency)

Specification	Value
Input requirements	
Rated input voltage	200 to 240 V AC
Rated input frequency	50 Hz to 60 Hz
Rated input current	4.0 A at 200 V AC 3.3 A at 240 V AC
Maximum rated input power	803 W at 200 V AC 798 W at 240 V AC

Btus per hour	2739 at 200 V AC 2724 at 240 V AC
Power supply output	
Rated steady-state power	750 W at 200 V AC to 240 V AC input
Maximum peak power	750 W at 200 V AC to 240 V AC input

HPE 750W Common Slot Gold Hot Plug Power Supply (92% efficiency)

Specification	Value
Input requirements	
Rated input voltage	100 to 120 VAC, 200 to 240 VAC
Rated input frequency	50 Hz to 60 Hz
Rated input current	8.9 A at 100 VAC 4.3 A at 200 VAC
Rated input power	857 W at 100V AC input 824 W at 200V AC input
BTUs per hour	2925 at 100V AC input 2812 at 200V AC input
Power supply output	
Rated steady-state power	750 W at 100V to 120V AC input 750 W at 200V to 240V AC input
Maximum peak power	750 W at 100V to 120V AC input 750 W at 200V to 240V AC input

HPE 750W Common Slot Platinum Plus Hot Plug Power Supply (94% efficiency)

Specification	Value
Input requirements	
Rated input voltage	100 to 120 VAC, 200 to 240 VAC
Rated input frequency	50 Hz to 60 Hz
Rated input current	8.5 A at 100 VAC 4.1 A at 200 VAC
Maximum rated input power	843 W at 100V AC input 811 W at 200V AC input
Btus per hour	2878 at 100V AC input 2769 at 200V AC input
Power supply output	
Rated steady-state power	750 W at 100V to 120V AC input 750 W at 200V to 240V AC input
Maximum peak power	750 W at 100V to 120V AC input 750 W at 200V to 240V AC input

HPE 750W Common Slot -48VDC Hot Plug Power Supply (94% efficiency)

Specification	Value
Input requirements	—
Rated input voltage	-36 V DC to -72 V DC -48 V DC nominal input
Rated input current	23 A at -36 V DC input 17 A at -48 V DC input, nominal input 11 A at -72 V DC input
Rated input power (W)	815 W at -36 V DC input 805 W at -48 V DC input, nominal input 795 W at -72 V DC input
Rated input power (Btus per hour)	2780 at -36 V DC input 2740 at -48 V DC input, nominal input 2720 at -72 V DC input
Power supply output	—
Rated steady-state power (W)	750 W
Maximum peak power (W)	750 W



CAUTION: This equipment is designed to permit the connection of the earthed conductor of the DC supply circuit to the earthing conductor at the equipment.

If this connection is made, all of the following must be met:

- This equipment must be connected directly to the DC supply system earthing electrode conductor or to a bonding jumper from an earthing terminal bar or bus to which the DC supply system earthing electrode conductor is connected.
- This equipment must be located in the same immediate area (such as adjacent cabinets) as any other equipment that has a connection between the earthed conductor of the same DC supply circuit and the earthing conductor, and also the point of earthing of the DC system. The DC system must be earthed elsewhere.
- The DC supply source is to be located within the same premises as the equipment.
- Switching or disconnecting devices must not be in the earthed circuit conductor between the DC source and the point of connection of the earthing electrode conductor.



CAUTION: To reduce the risk of electric shock or energy hazards:

- This equipment must be installed by trained service personnel, as defined by the NEC and IEC 60950-1, Second Edition, the standard for Safety of Information Technology Equipment.
- Connect the equipment to a reliably grounded SELV source. An SELV source is a secondary circuit that is designed so normal and single fault conditions do not cause the voltages to exceed a safe level (60 V DC).
- The branch circuit overcurrent protection must be rated 24 A.

HPE 1200W Common Slot Platinum Plus Hot Plug Power Supply (94% efficiency)

Specification	Value
Input requirements	

Rated input voltage	100 to 120 VAC, 200 to 240 VAC
Rated input frequency	50 Hz to 60 Hz
Rated input current	9.1 A at 100 VAC 6.7 A at 200 VAC
Maximum rated input power	897 W at 100V AC input 1321 W at 200V AC input
Btus per hour	3408 at 120V AC input 4433 at 200V to 240V AC input
Power supply output	
Rated steady-state power	800 W at 100V AC input 900 W at 120V AC input 1200 W at 200V to 240V AC input
Maximum peak power	800 W at 100V AC input 900 W at 120V AC input 1200 W at 200V to 240V AC input

Hot-plug power supply calculations

For hot-plug power supply specifications and calculators to determine electrical and heat loading for the server, see the Hewlett Packard Enterprise Power Advisor website (<http://www.hpe.com/info/rackandpower>).

Acronyms and abbreviations

DDR

double data rate

DMI

Desktop Management Interface

FBWC

flash-backed write cache

iLO

Integrated Lights-Out

IML

Integrated Management Log

LFF

large form factor

LOM

LAN on Motherboard

NMI

nonmaskable interrupt

NVRAM

nonvolatile memory

PCIe

Peripheral Component Interconnect Express

POST

Power-On Self Test

QPI

QuickPath Interconnect

RBSU

ROM-Based Setup Utility

SAS

serial attached SCSI

SATA

serial ATA

SD

Secure Digital

SFF

small form factor

TPM

Trusted Platform Module

UID

unit identification

USB

universal serial bus

Documentation feedback

Hewlett Packard Enterprise is committed to providing documentation that meets your needs. To help us improve the documentation, send any errors, suggestions, or comments to Documentation Feedback (<mailto:docsfeedback@hpe.com>). When submitting your feedback, include the document title, part number, edition, and publication date located on the front cover of the document. For online help content, include the product name, product version, help edition, and publication date located on the legal notices page.

Index

A

AC power supply 29, 87, 88, 89, 90
access panel 27

B

battery 57
buttons 72, 74, 77

C

cables 63
cabling 63
cabling, server 63
cache module 40, 41
capacitor pack 41
cautions 26, 27
chipset SATA cable 65
components 15, 18, 25, 72
components, identification 15, 72
components, system board 80
connectors 72
CSR (customer self repair) 5, 15
customer self repair (CSR) 5, 15

D

data recovery 42
DC power supply 30
diagnostic tools 69
diagnostics utility 69
DIMMs 48
drives 28, 72, 82, 83
drives, determining status of 83
DVD tray 37
DVD-ROM cabling 65
DVD-ROM drive 65
DVD-RW drive 65

E

electrostatic discharge 26
environmental specifications 86
expansion boards 47
extending server from rack 26

F

fan blank 37, 39, 40
fan LED 80
fan modules, installation 39

fan modules, removal 30, 36, 37, 39
FBWC cabling 64
FBWC module 41
features 72
FlexibleLOM 43
front panel components 72
front panel LEDs 74
front video adapter 43

H

hard drive backplane cabling 63
hard drive bays 72
hard drive bezel blanks 15
hard drive blanks 28
hard drive cage 36, 37
hard drive LEDs 83
hard drives, determining status of 83
hardware kit 15
health LEDs 74
heatsink 49
hot-plug power supply calculations 91
HPE Insight Diagnostics 25, 69
HPE Insight Diagnostics survey functionality 69
HPE Systems Insight Display LED combinations 80, 81

I

identifying components 72
illustrated parts catalog 15
iLO NIC LED 76
IML (Integrated Management Log) 70
Insight Diagnostics 69
Integrated Management Log (IML) 70
internal cables 63
internal USB functionality 71

L

LED, power on 74
LED, system power 74
LED, UID 74, 77
LEDs 81, 83
LEDs, front panel 83
LEDs, hard drive 83, 84
LEDs, NIC 77, 78
LEDs, power supply 77, 78
LEDs, SAS hard drive 83
LEDs, unit identification (UID) 77

M

management tools 69
mechanical components 15
memory slot LEDs 80

N

NIC connectors 76
NMI header 80

O

overtemperature LED 80

P

part numbers 15, 18
PCI riser board 46
PCI riser board slot definitions 74, 76
PCI riser cage 46
plastics kit 15, 18
power calculator 91
power LEDs, system 74
Power On button 74
power supplies 29, 30, 87, 88, 89, 90
power supply 29, 30, 91
power supply bays 76
power supply blank 29
power supply LEDs 80
power supply specifications 87, 88, 89, 90
powering down 25
preparation procedures 25
processor tool 52
processors 52

R

rack bezel 45
rack, extending server from 26
RBSU (ROM-Based Setup Utility) 70
rear panel buttons 77
rear panel components 76
rear panel LEDs 77
removal and replacement procedures 18, 25
replacement procedures 18, 25
required tools 18, 25
ROM-Based Setup Utility (RBSU) 70

S

safety considerations 26
safety information 26
SATA cabling 65
SATA drives 82
serial connector 76
server specifications 86
server warnings and cautions 27
specifications 86, 87, 88, 89, 90, 91

specifications, environmental 86
specifications, power 86, 87, 88, 89, 90
specifications, server 86
static electricity 26
symbols on equipment 26
system battery 57
system board components 78
system components 18
system maintenance switch 79
system power LED 74
Systems Insight Display 80, 81
Systems Insight Display LED combinations 81
Systems Insight Display LEDs 80, 81

T

T-10/T-15 Torx screwdriver 25
telco racks 25
temperature, overtemperature LED 80
tool, processor 52
tools 25
TPM (Trusted Platform Module) 62
troubleshooting 69
troubleshooting resources 63, 69, 72, 86
Trusted Platform Module (TPM) 62

U

UID button 77
UID LED 77
USB (universal serial bus) 70
USB connector 72, 76
USB support 70
utilities 69
utilities, deployment 70

V

video connector 72, 76

W

warnings 27